

COLLECTIVE AGREEMENT

Between

HIGHLAND VALLEY COPPER

and USWA Local 7619

Effective October 1, 2003 to September 30, 2006

00163(07)

INDEX

	Page
PREAMBLE	1
ARTICLE 1	
Definitions	2
ARTICLE 2	
Management Rights	4
ARTICLE 3	
Union Security	6
ARTICLE 4	
No Strikes, No Lockouts	13
ARTICLE 5	
Procedure for Settling Disputes	14
ARTICLE 6	
Arbitration	19
ARTICLE 7	
Discharge and Discipline	21
ARTICLE 8	
Officers, Committees and Stewards	23
ARTICLE 9	
Seniority	27
ARTICLE 10	
Job Postings	37
ARTICLE 11	
Health, Safety and Environment,	48
ARTICLE 12	
Hours of Work	63
ARTICLE 13	
Overtime and Special Pay	70

ARTICLE 14	
Paid Holidays	77
ARTICLE 15	
Wages	82
ARTICLE 16	
Vacation With Pay	84
ARTICLE 17	
Leave of Absence	91
ARTICLE 18	
Insurance Benefits	97
ARTICLE 19	
General Provisions.....	104
ARTICLE 20	
Trades Assignment	110
ARTICLE 21	
Technological Change	115
ARTICLE 22	
Training	118
ARTICLE 23	
Apprenticeship Program and Trades Training	129
ARTICLE 24	
Term of Agreement	138

APPENDIX A

Effective Dates for Rate Classifications in Appendix B	141
---	-----

APPENDIX B

Wage Grade Schedules

Wage Grade 9	145
Wage Grade 8	145

Wage Grade 7	146
Wage Grade 6	146
Wage Grade 5	147
Wage Grade 4	147
Wage Grade 3	147
Wage Grade 2	147
Wage Grade 1	147

Rates for Indentured Apprentices	148
---	------------

Wage Grade Qualifications Administration, Accounting and M.I.S.	149
--	-----

Management Information System (Operators & Programmers)	150
--	------------

Warehouse and Purchasing (Materials Management)	152
--	------------

Mine Engineering	152
-----------------------------------	------------

Milling	153
--------------------------	------------

Mine and Mill Departments	155
--	------------

LINES OF PROGRESSION

Diagrams	
Mine Operations	161

Mine Maintenance	162
Mine Engineering	163
Mill Department Operations	164
Mill Department Maintenance	165
Mill Technical	166
Administration Department Materials Management	167
Administration Department Accounting and Management Information Systems	168
Letters index	169
ADDENDUM "A"	
Human Rights Policy	172
Letters of Understanding	182

**PREAMBLE
AND
ARTICLES
1 TO 24**

THIS AGREEMENT made the 19th day of
January, 2004.

BETWEEN:

HIGHLANDVALLEY COPPER
(hereinafter called the "Company"),

OF THE FIRST PART

- and -

UNITED STEELWORKERS OF AMERICA
LOCAL 7619
(hereinafter called the "Union"),

OF THE SECOND PART

PREAMBLE

WHEREAS the parties agree that it is mutually beneficial and desirable to promote cordial relations and to set forth herein the agreement concerning rates of pay, hours of work and conditions of employment to be observed between the parties and to provide a method for the orderly adjustment of difference and grievances: WITNESSETH, in consideration of the mutual covenants and agreements herein set forth, the parties hereto have mutually agreed as follows:

ARTICLE 1 - DEFINITIONS

COMMITTEEMEN

An employee elected or otherwise appointed to serve on any committee referred to in this Agreement.

STEWARD

An employee selected or appointed by the Union to represent employees in a Department.

ENTRY LEVEL **JOB**

A job identified by an asterisk in "Lines of Progression" charts appended to this Agreement.

LINES OF PROGRESSION

A progression system listed in charts appended to this Agreement.

EMERGENCY

Any sudden or unusual occurrence or condition that could not by the exercise of reasonable judgment have been foreseen by the Company.

RECOGNITION

1.01 (a) The Company recognizes the Union as the sole and exclusive bargaining agent for all the Company's employees, employed at or from its operations located in the Highland Valley and the operations related thereto, except persons excluded by the Certification granted by the Labour Relations Board, supervisors, drafting

office staff, members of the security force, fire chief, first aid officer and all present office support **staff** employed in a confidential capacity. In the event any additional confidential support staff are added, the parties agree to discuss the matter and attempt to resolve same prior to making application pursuant to the Labour Relations Code.

1.01 (b) The word "employee" or "employees" whenever used in this Agreement refers to such employees as are covered by this Agreement. Words imparting the masculine gender shall include the feminine and vice-versa.

1.01 (c)

- i) The Company and Union agree that there shall be no discrimination against any employee because of a person's race, colour, ancestry, place of origin, political belief, religion, marital status, family status, physical or mental disability, sex, sexual orientation, age, Union membership or activity, or because of a criminal or summary conviction that is unrelated to the employment or intended employment of that person.
- ii) The Company shall ensure that all employees of Highland Valley Copper are assured of a work environment that is free of all forms of discrimination including personal and sexual

harassment. To meet this objective, the Company and the Union have developed a "Human Rights Policy" which is appended as Addendum "A" in this collective agreement.

1.02 The Company and the Union shall cooperate fully in the promotion and achievement of the matters set forth in the preamble to this Agreement.

1.03 The Company recognizes that it is not the function of persons of or above the rank of Supervisor to perform work which is normally performed by an employee in the bargaining unit, except under emergency conditions or for the purpose of instruction or experimentation.

1.04 In the event a person of or above the rank of Supervisor performs work in violation of Article 1.03 then the Company shall pay as a penalty an amount equal to the hourly rate of the employee who would normally perform such work for the period of the violation, (minimum one (1) hour) and payment will be made to the Union.

ARTICLE 2 - MANAGEMENT RIGHTS

2.01 Subject to the provisions of this Agreement, the Union acknowledges that the Company has and shall retain the sole, exclusive and undisputed right and responsibility

to manage its mines, plants and business, including but not limited to the following:

2.01

- (a) to plan, direct and control operations, to schedule production and other activities, to determine the products to be produced and the methods, processes and means of production or other work, to determine the location of plant facilities and the extent to which the plant or part thereof shall be operated.

- (b) to hire, promote, demote, classify, transfer, assign, reassign, and lay off employees and to discipline, suspend and discharge employees for just cause. A claim that an employee has been disciplined, suspended or discharged without just cause may be the subject of a grievance procedure hereinafter described.

- (c) to direct the working forces, including the right to decide on the number of employees needed by the Company, or the number of employees required for any task at any time, to change the number of employees assigned to any task, to organize the work, to assign the work, to schedule shifts, to maintain order, discipline and efficiency in the operations. The Company shall advise the Union seven (7) days in advance of impending shift schedule changes in writing

except where operational considerations do not permit.

- (d) to make and alter reasonable rules and regulations to be observed by all employees. The Company shall discuss with the Union any new or changed rule and post it on all bulletin boards prior to implementation.
- (e) On June 1, 1999, to retire to pension all employees who are 65 years of age and older, and thereafter to retire employees on attaining 65 years of age.

ARTICLE 3 - UNION SECURITY

3.01 Each employee shall, as a condition of his hiring or continued employment:

- (a) authorize the Company in writing to deduct union dues from his pay. The authorization shall be in a form agreed to between the Company and the Union.
- (b) become a member of the Union and maintain membership.

3.02

- (a) The Company agrees to deduct from each employee who has authorized such deduction, an amount equivalent to the monthly dues provided for in the

International Constitution of the United Steelworkers of America. Such deduction shall appear on each employee's **annual** Statement of Remuneration(T4 slip).

- (b) The Company shall endeavour to forward to the Union the total amount so deducted with an itemized statement of same in duplicate within ten (10) working days of the date of the payroll on which the deduction is made, in the manner provided for in sub-section 3.02 (e) hereof.
- (c) Total earnings shall be deemed to include base rate earnings and all premiums (if any) including shift differential, vacation pay, statutory holiday pay, overtime pay, call-in and reporting pay, but shall not include any Workers' Compensation payments, and payments under any benevolent, sickness or accident plans.
- (d) The reference period shall be the two (2) week period immediately prior to the payday in which the dues are deducted.
- (e) Dues shall be deducted each pay period and forwarded to the Union together with a complete summary of the Union Dues to the person and in the manner as advised from time to time by the Union. The duplicate itemized statement shall be forwarded to the Union.

3.03

- (a) Upon receiving a signed United Steelworkers of America District 3 Union Assistance Plan Deduction Authorization Form, the Company agrees to deduct not more than once each month from the earnings of every employee dues for the United Steelworkers of America District 3 Union Assistance Plan in such sum as the Union shall from time to time advise the Company in writing. The total amount **so** deducted with an itemized statement of same shall be forwarded to the Local Union prior to the end of the month next following that to which said deductions apply, in the manner provided in Sub-section (b) hereof.
- (b) All cheques shall be made payable to the United Steelworkers of America District 3 Union Assistance Plan; all cheques shall be forwarded **to** the Local Union.

3.04 The Company agrees to deduct on a bi-weekly basis the amount of (not less than \$0.01) per hour from the wages of all employees in the Bargaining Unit for all hours worked and, prior to the 15th day of the month following, **to** pay the amount **so** deducted to the "Humanity Fund" and to forward such payment to United Steelworkers of America National Office, 234 Eglinton Avenue East, Toronto, Ontario, M4P 1K7, and to advise in writing both the Humanity Fund at aforementioned address and the Local

Union that such payment has been made, the amount of such payment and the names of all employees in the Bargaining Unit on whose behalf such payment has been made.

It is understood and agreed that participation by an employee in the Union Assistance and Humanity Fund programs of deductions set forth above may be discontinued by any employee after the receipt by the Company and the Local Union of that employee's written statement of his desire to discontinue such deductions from his pay during the four weeks following ratification of this Agreement.

3.05 The Union agrees to indemnify the Company and save it harmless against any claims which may arise in complying with the provisions of this article.

3.06

- (a) The Company may employ students in reasonable numbers provided that no employee shall be laid off, failed to be recalled from layoff, discharged or displaced to make place for a student. All students will be employed as labourers, except where they possess qualifications not otherwise available from the existing work-force.

- (b) The Company and any student so employed agree that the employment of the student

shall be for a specified period not exceeding four **(4)** months and the expiry of that period shall be a just and reasonable cause for the termination of the student by August 31st each year. If the Company elects **to** retain a student as a regular employee, then the provisions **of** Article 9, sub-section 9.08 shall apply. Where students are hired as regular employees, their probationary period shall commence on the date they become regular employees. This paragraph is not intended to limit the employment **of** students during the Christmas school break, which is of short duration.

In the event of a lay-off, students shall be laid off before regular employees.

3.07

- (a) The Company recognizes the Union's concern over the use of contractors to do the work that the bargaining unit employees normally perform and, as such, agrees **to** continue its practice to perform operations and maintenance work with its own employees provided it has the manpower, skills, equipment and facilities **to do so**.

- (b) The Company hereby assures the Union that it will continue its general operating policy of placing primary reliance on its own employees **to** perform operations and maintenance work. To this end, the

Company agrees that operations and maintenance work currently performed by Highland Valley Copper employees in the Mine, Mill and Administration Departments will continue to be performed by members of the bargaining unit.

- (c) The Company agrees that sub-contract work, normally performed by members of the bargaining unit on the Company's premises, will be performed by Union Contractors. Thirty (30) days prior to any planned sub-contracting, the Company will notify the Union of the name of the sub-contractor, the nature of the work to be performed, the approximate number of sub-contractor's employees, the number of days to be employed and their Union affiliation. Within thirty (30) days of the expiration of the sub-contracting work, the Company will submit to the Union the actual number of man hours to complete the job. If notice is not given pursuant to this article 3.07 (c) the facilitator named in article 3.07 (d) may after investigation, award a remedy to the union for violation of this paragraph 3.07(c).

- (d) Within thirty (30) days of the execution of this Collective Agreement, the Company and Union will establish a Joint Committee to review contracting out practices. The Joint Committee will be composed of four (4) representatives of the Union and four (4)

representatives of the Company and shall include management and union representatives who are familiar with trades work and contracting practices. The parties further agree that V. Ready will act as a facilitator to ensure that the procedures of the Committee are carried out. The terms of reference of the Committee shall be:

- i) to establish a list of work that has historically been contracted out because of the need for specialized skills, specialized equipment and the lack of facilities;
- ii) to review contracted work, including warranty work, with a view to what other options may have been possible and practicable, and the goal of replacing contractors with Highland Valley Copper bargaining unit employees.
- iii) to preview work expected to be contracted out and explore possible alternatives taking into consideration the efficiency of the operations, the urgency of the work to be performed and the availability of equipment, skills and manpower;
- iv) to make recommendations to the parties respecting contracting of work as set out in ii) and iii) above.

- (e) No employee shall be displaced, or laid off, or have their right to recall deferred as a result of contracting out, or as a result of a contractor's employee(s) performing warranty work.

- (f) The parties agree that the respective co-chairpersons of the joint committee will attempt to resolve all disputes arising from contracting out practices at Highland Valley Copper prior to the union filing grievances. When the co-chairpersons can not resolve a dispute, the union may refer the dispute to the grievance procedure.

ARTICLE 4 - NO STRIKES NO LOCKOUTS

4.01 The Union agrees that neither the Union nor its officers, nor its members, shall in any way authorize, encourage or participate in any strike, work stoppage, walk-out, slow-down, or any act of a similar nature which would interfere with, limit, or impede production during the term of this Agreement.

4.02 In case any of the aforementioned acts restricting or eliminating production should occur in violation of the above, the Company shall have the right to discharge or discipline any or all of the employees taking part in such act or acts, providing, however, that any such action by the Company shall be subject to the grievance

procedure if any employee believes he has been discharged or disciplined unjustly.

4.03 The Company agrees that there shall be no lock-out of employees during the term of the Agreement.

ARTICLE 5 - PROCEDURE FOR SETTLING DISPUTES

5.01

- (a) The parties agree that it is desirable that any complaints or grievances should be adjusted as quickly as possible. Employees are therefore urged to try to settle their complaints with their Supervisor as soon after they originate as possible.

- (b) The Company is willing to meet any of *its* employees, or their representatives, for the purpose of discussing grievances or complaints with the object of reaching a satisfactory solution. In the event of any meeting between any employee(s) and Company representatives that occurs during working hours, such employee(s) shall be paid their hourly rate as defined in Article 19, Sub-section 19.08. In the event of any such meeting between any employee(s) and Company representatives that occurs outside regular working hours, such employee(s) shall be paid their hourly rate for the period of the meeting. Such meetings

shall be held at a mutually agreeable time or when requested during the first or last hour of the grievor's shift.

5.02

- (a) If an alleged violation of this Agreement affects more than one employee or affects the interests of the Union as a party to the Agreement, the Union may sign and file the grievance on behalf of the employee(s) specifying the alleged violation of the Agreement and, if identifiable, specifying name and department. Such grievances shall be presented at Step 2.
- (b) Grievances under Article 5.02 (a) and 5.02 (c) - Step 1, shall be presented in writing.
- (c) Should a dispute arise between the Company and any employee regarding the application, operation, interpretation or alleged violation of this Agreement, an earnest effort shall be made to settle the dispute in the following manner:

Step One

Within ten (10) days after the alleged grievance has arisen, or within ten (10) days from the time the employee should reasonably have known of the occurrence of the event, the employee and his Steward may present the grievance in writing to his Supervisor. Failing settlement to the

employee's satisfaction within three (3) days, the employee may process the grievance to Step 2.

Step Two

Within five (5) days from the time settlement could have been made in the previous step, the employee, accompanied by his Steward, and a member of the Grievance Committee, may present the grievance in writing to his Department Superintendent. The Department Superintendent shall reply in writing within five (5) days of the presentation of this grievance under Step 2. Failing a satisfactory settlement or reply at this stage, the employee may process the grievance to Step 3.

Step Three

Within five (5) days from the time settlement could have been made within the time limits of the previous Step, the employee, accompanied by his Steward, Chief Steward, Grievance Chair and/or Union President or designates thereof, and if requested a representative of the International Union may take the matter up with the Manager or his designate. Prior to submission to the Manager there shall be a written statement outlining the nature of the grievance, the remedy sought and the section or sections of the Agreement which are alleged to have been violated. Failing satisfactory settlement or reply within five (5) days the matter

may be referred to arbitration within thirty (30) calendar days from the date settlement could have been made in Step Three (3).

- (d) Where Step 3 has been exhausted and the matter has been referred to arbitration, the Local Union President or his designate and the Company representative may without prejudice attempt to resolve the matter. This may include the calling of witnesses in which case the provisions of 5.01 (b) shall apply with respect to the payment of wages.

5.03 In determining the time within which any step is to be taken under the foregoing provisions of this Article, Saturdays, Sundays and the recognized holidays shall be excluded. Any and all time limits fixed by this Article may be extended by mutual agreement between the Company and the Union.

5.04

- (a) Any agreement between the Company and the Union shall be final and binding upon the Company, the Union and the *employee(s)* concerned.
- (b) Answers shall be given in writing to the Union on a first, second and third stage grievance and shall be sent to the *grievor*, the Union Steward involved and the Chief Shop Steward.

5.05 If it is not practical to follow the steps in the Grievance Procedure because some department may have no Company or Union representative or the Company or Union representative is not available, then by mutual consent the next step may be proceeded to.

5.06 The grievance procedure shall be carried out on the Company's property or at such other place or time as the Union and the Company shall mutually agree upon. The Company and the Union agree that a grievance presented in Steps 2 and 3 shall be discussed at the meeting arranged to deal with said grievance(s).

5.07 If it is necessary for a Steward or other employee(s) to take time off during working hours in connection with a grievance, he must notify his supervisor and they must arrange a mutually satisfactory time. Time off shall not be unreasonably withheld.

5.08 Pursuant to Section 104 of the B.C. Labour Relations Code:

- (a) at any time following completion of Step 3 and prior to the appointment of an arbitrator pursuant to this article and where a difference arises between the parties relating to the dismissal, discipline, or suspension of any employee, or to the interpretation, application, operation, or alleged violation of this agreement,

including any question to whether a matter is arbitrable, during the term of the collective agreement, Vince Ready, Merv Chertkow, B. Greyell, or a substitute agreed to by the parties, shall at the request of either party:

- i) investigate the difference;
 - ii) define the issue in the difference; and
 - iii) make written recommendation to resolve the difference within five (5) days of the date of receipt of the request; and for those five (5) days from that date, time does not run in respect of the grievance and/or Arbitration Procedure.
- (b) if mutually agreed, the recommendations shall become a decision binding upon the parties and all others affected.

ARTICLE 6 - ARBITRATION

6.01 Either party must within thirty (30) calendar days upon the completion of Step 3 of the grievance procedure outlined in Article 5, notify the other party in writing of its desire to submit to arbitration an unsettled grievance relating to the application, operation, interpretation or alleged violation of this Agreement, including any question as to whether the matter is arbitrable.

6.02 Within seven (7) days following such notice, either party will notify one arbitrator selected from the following list:

1. M. I.Chertkow
2. Bruce Greyell
3. D.C. McPhillips
4. C. Taylor

Selection of an arbitrator for the first arbitration shall be in alphabetical order until an available arbitrator is found. If none of the arbitrators listed above are available, an appointment shall be made by the Minister of Labour of the Province of British Columbia upon request of either party.

6.03 The Arbitrator shall hear and determine the difference or allegation and shall within a maximum of thirty (30) days following arbitration render his decision.

6.04 The parties shall jointly bear the costs of the arbitrator. Each of the parties shall bear the expenses of the witnesses called by it. No costs of arbitration shall be awarded to or against either party.

6.05 Arbitration procedures shall be expedited by the parties.

6.06 At arbitration, the parties may have the assistance of the employee(s) concerned and any necessary witnesses. All reasonable

arrangements shall be made to permit the conferring parties access to the property to view the operations in question and to confer with the necessary witnesses.

6.07 An arbitrator named in accordance with this Article shall be governed by the provisions of this Agreement and, subject only to the provisions of Article 15, Sub-section 15.03 shall not have the right to add to, delete from, to change, or make any decision contrary to the provisions of this Agreement. The decision of the arbitrator shall be final and binding on both parties. Except as otherwise provided in this Agreement, no arbitrator may award retroactively beyond ten (10) days preceding the date of the written grievance.

6.08 Except where specifically provided otherwise by statute, the parties agree to abide by the provisions of Article 5 and Article 6 as the only means of resolving any difference which may arise during the term of this Agreement. All employees shall continue to work as usual without curtailment or restriction of normal production, and the Company shall not lock-out the employees.

ARTICLE 7 - DISCHARGE AND DISCIPLINE

7.01 If it is alleged that an employee has been discharged without just cause the grievance shall start at Step 3 and if it is alleged that an

employee has been suspended without just cause the grievance shall start at Step 2 of the grievance procedure, within five (5) working days. The discharged or suspended employee shall be given the opportunity of seeing a Steward and/or Union President before he is required to leave the premises.

7.02 If it is agreed or decided at any stage of the grievance procedure, except arbitration, that an employee has been suspended or discharged without just cause, the Company shall reinstate him in his job without loss of seniority. A reinstated employee is to be paid his wages at his hourly rate for the time loss limited to a maximum of the employee(s) regular number of hours per week, less amounts earned during the time loss.

7.03 Where an arbitrator has been selected to determine a question respecting an alleged unjust discharge or suspension, he shall have power and jurisdiction to:

1. uphold the discharge or suspension, OR
2. vary the penalty, OR
3. substitute a different penalty, OR
4. direct reinstatement,

and in cases 2, 3, and 4 may in addition order the Company to pay the employee full or partial

compensation (less any amounts of money earned by the aggrieved employee during any time loss) in accordance with his hourly rate. It is understood, however, that if an employee is reinstated, he shall retain his full seniority.

7.04

- (a) Only Written Warnings, Final Written Warnings and Letters of Suspension shall be considered as a form of discipline and shall be subject to the provisions of the Grievance Procedure. A copy of every Written Warning, Final Written Warning and Letter of Suspension issued shall be sent to the Union.

- (b) Written Warnings, Final Written Warnings and Suspensions shall be deemed void after one (1) year from date of issue.

7.05 A Shop Steward in the department and on the shift shall be present when Written Warnings, Final Written Warnings and Suspensions are handed out.

ARTICLE 8 - OFFICERS, COMMITTEES AND STEWAFDS

8.01

- (a) The Union may appoint stewards from each crew in each section in the following manner:

- i) where there are normally fewer than twenty (20) employees on a crew there shall be no more than one (1) steward appointed.
 - ii) where there are normally more than twenty (20) employees on a crew there may be one (1) additional steward for every twenty (20) employees to a maximum of four (4) stewards per crew.
- (b) The appointed grievance committee shall be comprised of not more than thirteen (13) members including the grievance chair, all of whom must have completed their probationary period.

8.02 The Union shall notify the Company in writing of the names of all Officers, Committeemen, Stewards and members of the Grievance Committee and of any changes in the same. The Company shall post the names and titles of first line supervisors.

8.03 The Union Officers, Grievance Committee members and Stewards shall notify their supervisors and they shall arrange a mutually satisfactory time to leave their work to attend to their duties as outlined in this Agreement. They shall be paid their hourly rate, as defined in Article 19, Sub-section 19.08, for the hours that they were scheduled to work if they attend

meetings which are held during their regular working hours.

8.04

- (a) The functions of Stewards and Grievance Committee members are to consider, investigate and attempt to settle grievances. If in the course of investigating a grievance, a Steward or Committeeman enters a department or section of the operation other than that of their authorized work place, or if it involves the investigation of the condition of equipment, they must notify the responsible member of supervision and they shall arrange a mutually satisfactory time for such investigation. A supervisor shall accompany the Steward or Committeeman to the place where the investigation is to be carried out. It is understood that the Steward or Committeeman upon reaching the place where the investigation is to occur, shall have the opportunity of consulting privately with the employee(s) concerned.
- (b) The Company will pay to the Union a payment equal to eighty (80) hours per week at the highest hourly wage grade rate for the purposes of dealing with Union business pertaining to the internal administration of this Agreement. In this regard the Company will grant leaves of absence for the Union President and Union officers as advised in writing by the Union.

- (c) The Chairmen of the Local Union Safety and Health, Grievance and Contracting Out Committees shall be assigned to the dayshift Monday through Friday. The Union Bargaining committee shall also be assigned to the dayshift during that period of time when they are preparing for and during contract negotiations.

- (d) 1. Individuals referred to in 8.04(c) above shall be paid their hourly rate, as defined in Article 19, subsection 19.08, for any time lost as result of being transferred to the dayshift.

- 2. Employees granted Union leave will have their wages maintained by the company. The company will submit to the Union for reimbursement an amount equivalent to the Company's cost, once per month.

8.05 The Company shall provide designated separate departmental bulletin boards for the exclusive use of the Union, where officers of the Union shall post notices pertaining to:

- (a) time, place and type of Union meetings;

- (b) notices as to Union nominations and elections;

- (c) list of Union Officers and Stewards;

(d) notices of Union social affairs.

8.06 Supervisors will make an earnest effort during the first shift to introduce new employees to their Shop Steward and Union Safety Representative. A new crew member will be introduced to his Shop Steward and Safety Representative.

ARTICLE 9 - SENIORITY

9.01 The parties recognize that job opportunity and security shall increase in proportion to length of service. It is therefore agreed that in all cases of training, vacancy, promotion, demotion, transfer, lay-off, termination and rehiring after lay-off or termination, senior qualified employees shall be entitled to preference.

9.02 All employees who have not completed three hundred twenty (320) hours worked within a six **(6)** month period shall be considered probationary employees and shall have no seniority rights. They may be discharged at the Company's discretion. Such employees shall have the right to grieve in respect to any matter other than his seniority.

9.03 Upon completion of the probationary period, an employee shall acquire seniority starting at that time and the employee's name shall be entered on the seniority lists according to his most recent hiring date.

9.04 There shall be two (2) types of seniority; namely Company and Departmental:

- (a) the Company seniority of an individual means the length of time of his continuous service with the Company since his last hiring by the Company.
- (b) Departmental seniority, for the purpose of Articles 9 and 10, shall mean the length of an employee's service within the following departments; Mine, Mill and Administration.
- (c) For the purposes of this agreement, an employee's seniority shall be the seniority he held with either **Cominco Ltd./Valley Mine** (including seniority with Bethlehem Copper) or **Lornex Mining Corporation Ltd.** at July 1, 1986.

9.05 An employee shall accumulate seniority during his normal employment and seniority shall be maintained and continue to be accumulated during:

- (a) An absence due to an occupational accident while the employee is performing work for the Company.
- (b) The period of time an employee is absent and in receipt of Weekly Indemnity benefits as described in Article 18, Sub-section 18.01 (h) of this Agreement.

- (c) The period of time an employee is absent and in receipt of Long Term Disability benefits as described in Article 18, **Sub-section 18.01 (i)** of this Agreement.
- (d) An absence due to **Maternity/Paternity Leave**.
- (e) A Leave of Absence approved pursuant to Article 17, Sub-section 17.01 (d).
- (f) If an employee is transferred from the bargaining unit to a supervisory or staff position, he shall retain his seniority in the bargaining unit for a maximum period of 100 working shifts, regardless of whether he works the 12 hour, 10 hour or 8 hour shift schedule.

The Company shall supply to the Union, monthly, an up to date list of the employees being utilized in a supervisory or staff position, detailing the number of days worked year to date.

- i) When recording temporary supervisor working shifts, the company will:
 - Record the time in full shifts, even if the individual only worked a partial shift.
 - Track and flag the system at 90 working shifts to warn that a temporary supervisor is

approaching the maximum 100
working shifts

- ii) Acting supervisors, on vacation, will not be brought in on overtime to work except in the case of an emergency, as outlined in the collective bargaining agreement preamble.
- iii) Employees will be charged in full days while being trained by the company to perform the duties of a supervisor or staff position.
- iv) Bargaining unit employees accepting a relief supervisor's job will remain as the relief supervisor until the end of the shift.

9.06 An employee shall maintain but not accumulate seniority during layoff on the following basis:

- (a) Employees with less than one **(1)** year of service shall retain their seniority for a period of one **(1)** year.
- (b) Employees with more than one **(1)** year of service shall retain their seniority for eighteen **(18)** months, plus one **(1)** additional month for each year of service up to an additional twelve **(12)** months.

- (c) An employee returning from a lay-off will have his anniversary date moved by the same amount of days he was laid off for.

In the event of lay off, medical benefits will be continued to the end of the month following the month in which the lay off occurs.

9.07 An employee shall lose his seniority and his name shall be removed from all seniority lists for any one of the following reasons:

- (a) if he voluntarily quits his employment with the Company;
- (b) if he is discharged and not reinstated under the terms of this Agreement;
- (c) if he has been laid off due to lack of work for a period in excess of the time stipulated in Article 9, Sub-section 9.06;
- (d) if he is laid off and fails to contact the Company within seven (7) days and fails to return to work within fourteen (14) days after he has been notified by the Company by registered mail at his last known address unless he provides a reason which is acceptable to the Company;
- (e) if he is absent without permission from work for more than three (3) consecutive working days, unless he provides a proven reasonable excuse;

- (f) if he does not return to work within three (3) working days following the expiration of a leave of absence, unless he provides a proven reasonable excuse;
- (g) if he accepts severance pay under Article 21, Sub-section 21.03 (e);
- (h) if he accepts a permanent position outside the bargaining unit in the employ of Highland Valley Copper.

9.08 In the event a former employee is re-employed by the Company within ninety (90) days after having voluntarily quit, then following completion of his probationary period, such employee shall retain his original seniority date for purposes of vacation and pension credit entitlement only.

9.09

- (a) The Company shall, for information purposes, maintain up-to-date Company and departmental seniority lists showing each employee's order of seniority with his name, number and his service date. In cases of equality, seniority rank shall be determined by the date of birth in chronological order.
- (b) The seniority list shall be posted every three (3) months and a copy supplied to the Union.

9.10 An employee displaced from his job as a result of a decrease in the workforce or restructuring of the work-force shall be reassigned by the Company in accordance with Article 9.01. Such re-assignment must be made on the following basis:

- (a) To any job previously held within the Bargaining Unit on the basis of Company seniority, or;
- (b) To any job in his Line of Progression as outlined in Appendix "C", based on his Company seniority provided he has the qualifications to do the job, or if no job is available;
- (c) To any job within his department in accordance with Department seniority, provided he has the qualifications to do the Job, or, in the opinion of the Company could be trained to perform the job in a maximum period of four shift cycles, if no job is available;
- (d) To any job in the Company as designated in Appendix "C" with an asterisk, in accordance with Company seniority, provided he has the qualifications to do the job or in the opinion of the company could be trained to perform the job in a maximum period of four shift cycles, if no job is available:

- (e) Then, the employee affected may either displace the employee with the least seniority, provided he has the qualifications to do the job, elect to be laid off from the Company or accept severance under the terms of the collective agreement.

9.11

- (a) An employee exercising his right to bump under articles 9.10 (a) through (e), will displace the most junior employee within that classification where it results in the least amount of earnings lost to the employee who is bumping and assume the shift and department for that job.

- (b) An employee who has been displaced from his job or who has been laid off from the Company as a result of the application of the lay off procedure shall, when work becomes available, be entitled to be recalled on the basis of his seniority in accordance with Article 9, Sub-Section 9.01.

9.12 When opportunities or requirements exist for employees to change shifts or crews within their job classification and within their department, the company will review the department shift/Crew Transfer Request Forms and transfer employees using department seniority. If there are no volunteers, the

Company will transfer employees using Company seniority.

A Company representative and a representative designated by the Union will meet and establish a set of rules governing the Shift/Crew Transfer Request Form for their area or occupational group.

9.13 The layoff procedure outlined in Article **9**, Sub-section **9.10** shall not apply to a reduction in force due to interruptions of work of less than fourteen (**14**) days. In such cases, the following procedure shall apply:

- (a) based on Company seniority, employees shall be reassigned to displace the least senior employee on their shift occupying jobs within the department.
- (b) if reassignment cannot be made on the employees shift within the department, he shall displace the least senior employee on another shift within the department.
- (c) employees affected in (a) and (b) shall be required to accept the assignment.
- (d) the parties may, if there is sufficient advance notice of reduction in force as contemplated in this section, negotiate a lay-off procedure other than as described herein. Following mutual agreement such procedure will

replace the procedure described in Article 9.13 (a) (b) and (c).

- (e) the provisions of Article 9.06 (c) shall be waived and there shall be no loss of seniority to those employees affected by this Article.

9.14 An employee recalled to a job on which he has seniority rights shall return to that job, if he does not, he shall lose his right to that job. However, where an employee holding a job at wage grade 5 or higher is laid off and later is offered recall to a job below wage grade 5, such employee may decline to return without losing seniority and right to recall for any subsequent openings. Any laid off employee, who is offered recall for a period anticipated to be less than one month, may decline to return without losing his seniority and right to recall for any subsequent openings.

9.15 In order to protect their seniority, employees who are laid off must advise the Industrial Relations and Personnel Department in writing of any change of address.

9.16 The Local Union Officers - President, Vice President, Recording Secretary, Financial Secretary, Treasurer, Chair of the Grievance Committee, Chair of the Safety and Health Committee, who have acquired seniority shall be the last employees to be laid off from the

Company in the case of lay off, provided they can satisfactorily perform the available work.

9.17 Designated Individuals - it is expressly understood and agreed that notwithstanding anything in this Article contained, the Company shall have the right from time to time to designate to the Union individuals who agree to be given special experience or training in preparing them or trying out their capabilities for other or broader assignments with the Company or for future service other than to the Company not exceeding at any one time five (5) individuals, and to promote and demote such individuals and direct their efforts from time to time, free from any limitations provided for in this Article provided, however, that the employment of any such individuals shall not affect the seniority nor result in the demotion of any other employee.

ARTICLE 10 -JOB POSTINGS

10.01 Subject to procedures governing Lines of Progression all permanent jobs shall be posted. The selection of employees to fill posted jobs shall be based upon Company or Departmental Seniority as the case requires as set forth in this Article.

10.02

(a) Notice of all job vacancies that require posting shall be made known on all

Company Notice Boards within three (3) working days exclusive of Saturdays, Sundays and Statutory Holidays and remain on all Notice Boards for a period of seven (7) calendar days.

- (b) The notice that a vacancy exists shall be in the following form:

Date posted _____ Posting # _____
The following vacancy (vacancies) in
the _____ Department for the job(s)
of _____ on _____
crew _____ schedule _____
in which, on assignment, is paid for at the rate
of \$ _____ per hour, is announced.

Applications in writing shall be received by the
Applicant's foreman no later than
_____ (date to be seven (7)
calendar days after the date of posting).

Date

R.M. Chenier
Superintendent
Industrial Relations & Personnel

PLEASE NOTE THAT THE SENIOR,
QUALIFIED APPLICANT FOR THIS POSITION,
AS OF WHEN THIS POSTING EXPIRES, WILL
BE REQUIRED TO ACCEPT THIS POSITION.

- (c) Job Posting forms will be two **(2)** copies signed by the foreman; One (1) copy to the Company and one (1) to the applicant.

10.03 In awarding a Job Posting to an Entry Level job (identified by an asterisk (*) in the appendices), the Company, pursuant to Article 9.01, shall consider the Company seniority of each employee concerned in determining which employee shall be awarded the job.

10.04 In awarding a Job Posting to a department job above the Entry Level (identified by a check (✓) in the appendices), the Company, pursuant to Article 9.01, shall consider the department seniority of each employee concerned in determining which employee shall be awarded the job. If no successful applicants are found, based on departmental seniority, the Company shall award the job to the employee with the greatest Company seniority provided he possesses the minimum qualifications to do the job.

10.05

- (a) The Company will not be required to post jobs above jobs marked with an asterisk (*) or check (✓), provided there is a qualified employee within that Line of Progression.
- (b) In awarding a job above Entry Level jobs that are within a Line of Progression, the Company, pursuant to Article 9.01, shall consider the department seniority of each

employee within the Line of Progression in the job class immediately below in determining which employee shall be awarded the job.

- (c) Where a qualified employee in that Line of Progression is awarded the job, the Company will post the name and departmental seniority date of the employee who is awarded the job.
- (d) If there are no qualified employees within that Line of Progression, the Company shall post the job, and pursuant to Article 9.01, shall consider the department seniority of each concerned in determining which employee shall be awarded the job. If no successful applicants are found based on departmental seniority, the Company shall award the job to the employee with the greatest Company seniority provided he possesses the minimum qualifications to do the job.

10.06

- (a) When an employee elects not to advance in a Line of Progression, or elects not to take the additional training which would qualify him to advance in the Line of Progression, he will sign a waiver form supplied by the Company and submit it to his foreman. Employees who elect to freeze themselves in the Line of Progression will be paid at their current wage rate.

- (b) Employees who elect to freeze themselves in the Line of Progression must remain *frozen until the next employee in the Line of Progression has completed his training in the Line of Progression and has completed his training in the position the frozen employee would normally have been trained on.*

10.07

- (a) All job vacancies shall be filled in accordance with the provisions of Article 10.
- (b) All new job classifications, as contemplated in Article 15.03 shall be posted and filled in accordance with Article 10.02. The job shall be awarded to the senior applicant based on Company seniority provided the applicant has the qualifications to perform the work.

10.08

- (a) Qualified tradesmen wishing to work in another area or department where the same trade is being practiced will have the opportunity to move to that area or department if a vacancy is created.
- (b) Once it is determined that a vacancy exists the Company shall post the job in accordance with Article 10.02.
- (c) The Company shall award the job to the senior qualified tradesman.

- (d) No more than three (3) employees may change jobs as a result of each initial vacancy; then the Company may recruit.
- (e) Tradesmen who move into a new department or area as a result of a job posting will not be permitted to post out of that department or area for six (6) months.

10.09

- (a) Notice of all job postings filled in accordance with Article **10** shall be made known on all Department Notice Boards within three (3) working days, exclusive of Saturdays, Sundays and Statutory Holidays and shall remain on the Notice Boards for a period of seven (7) calendar days.
- (b) Every effort shall be made to enable the successful applicant to report to his new job within fourteen (**14**) calendar days from the date of acceptance. The successful applicant will be paid his new rate of pay when he reports to the job. If the successful applicant is held back longer than fourteen (**14**) calendar days, he shall be paid the rate of the newly posted position as long as it is higher than the employee's present rate. This will commence on the fourteenth (14th) calendar day.

10.10 If the posted job is in another department, the employee shall accumulate seniority in both

his existing as well as the new department from the date he is notified he is the successful applicant until the date he reports to the new job.

10.11 An employee may make application in anticipation of up to two (2) job vacancies that may occur while he is absent on vacation. Such application must be made prior to the commencement period, and shall include a detailed list of qualifications and experience suited to the potential vacancy. The applications shall be valid for the vacation period only. If a vacancy for which he has made application develops, and he is the successful candidate as determined through the application of Articles **10.02**, **10.03**, or **10.18**, then he must accept the position.

10.12

- (a) In the case of temporary vacancies which are not expected to exceed forty-five (45) regular working days:
- (i) the Company shall consider the department seniority of the employees on the shift on which the vacancy exists;
 - (ii) If there are no volunteers, the Company will assign the employee on the shift with the least Company seniority;
 - (iii) In the event the Company must go beyond the shift for a suitable

replacement, and there are no volunteers;

- (iv) then, the Company will assign the **departmental employee** with the least Company seniority.

- (b) If a temporary vacancy occurs for a period which exceeds forty-five (45) regular working days, but is not expected to exceed the duration of weekly indemnity benefit in the case of sickness or injury, or the length of time indicated in the Employment Standards Act for Pregnancy or Parental leave, then such vacancies shall be filled by the Company from within the department in accordance with departmental seniority from the line of progression or back up **list** or trained operators list where applicable. If the Company is unable to fill the position from within the department, or if the position is a bid entry position, the Company shall post the temporary vacancy in all departments and fill the position using company seniority. In the event an employee's absence is for a longer period of time, the vacancy shall be filled in accordance with provisions of the job posting procedure.

- (c) When an employee is awarded a position which is a result of a temporary vacancy which exceeds forty-five (45) regular working days, the Company will post the

name and seniority of the employee who is awarded the job.

- (d) Where an employee must change departments as a result of being awarded a temporary posting such employee shall only accumulate seniority in the department where the temporary vacancy exists. An employee will not, except as agreed to in article 10.10, simultaneously accumulate department seniority in two departments.

10.13

- (a) An employee who has been absent from work and in receipt of Workers' Compensation, Weekly Indemnity or Long Term Disability benefits shall return to his former job provided he is reported by his doctor to be fit to return to work and perform the work in question.
- (b) When such employee cannot produce the necessary medical approval; he may, subject to the provisions of Article 9 and 10, bump into any job, provided that he has;
 - i) the present necessary skill, ability, and physical capability to perform the job; and
 - ii) Company seniority; and
 - iii) produces a satisfactory medical report reflecting his fitness to perform the job.

- (c) An employee no longer capable of performing work within his classification as a consequence of injury or illness and does not fall under (a) above may exercise his rights under (b) above.

10.14 An employee accepting a job posting must remain in the posted job for a period of six (6) months before applying for another job posting, with the exception of those who are accepted as applicants in the Apprenticeship Training Program or those who want to move laterally to a permanent opening within the same classification. This six (6) month period shall commence on the 14th day from the date the employee becomes the successful applicant.

10.15 When a job is moved to another department and the holder of such a job is by reason thereof transferred to such other department, the employee shall be a member of his new department and he shall retain all accumulative seniority.

10.16 The Company will send a copy of all job postings to the Union and will provide the Union with a list of all employees who applied to the posting along with the name of the successful applicant.

10.17 Employees may be temporarily assigned to another department or work area for a maximum period of twenty-eight (28) calendar days or for a total cumulative period not

exceeding sixty (60) calendar days in one (1) calendar year. It is recognized that the Company **shall have the** right to **assign employees** out of line of seniority for a maximum period of twenty-eight (28) calendar days, to utilize their special skills or experience while training a more junior employee to fill a vacancy. The provisions of this Article shall not apply to apprentices.

10.18

To be used when canvassing employees:

- on a Back-up or Trained Operators List

INFORMATIONAL POSTING

Date posted: _____ Posting#: _____

The following vacancy (vacancies) in

the _____ Department for the job(s)

of _____ on _____

crew _____ schedule _____

in which, on assignment, is paid for at the rate

of \$ _____ per hour, is announced.

Applications in writing shall be received **by** the

Applicant's foreman no later than

_____ (date to be seven (7)

calendar days after the date of posting).

Date

R.M. Chenier
Superintendent
Industrial Relations & Personnel

ARTICLE 11 - HEALTH, SAFETY AND ENVIRONMENT

11.01 The Company and the Union acknowledge their common concern for maintaining a safe and healthy working environment to prevent industrial injury and illness. In order to effect a thoroughly understood and accepted Safety and Health Program for employees at work, it is agreed that joint and cooperative methods shall be encouraged.

To this end, Joint Occupational Health, Safety and Environment Committees will be established. In addition, the President of the Local Union, the Chairman of the Health, Safety and Environment Committee of the Union, the appropriate Departmental Safety Representative and/or Crew Safety Representative and, with the permission of the Industrial Relations and Personnel Department, a representative of the International Union shall have the right at any time to discuss matters dealing with health, safety and environmental conditions and shall have the right of access to the Company's operations to investigate such matters. Access for such investigations shall be arranged expeditiously if requested, and Company officials shall accompany the Union officials on such investigations.

The Company shall continue to make provisions for the health, safety and environment of the employees.

11.02

- (a) The Joint Occupational Health, Safety and Environment Committee (OHSC) shall be composed of the Superintendent Safety, the Superintendent Environment Services, the Union Health and Safety Chairman and the departmental area safety representatives. There shall be two (2) co-chairmen, one (1) a Union representative and the other, a Company representative.
- (b) All accidents, dangerous occurrences and near-miss incidents shall be investigated by persons knowledgeable in the type of work involved and the co-chairmen of the OHSC or their designates.
- (c) The Joint Review Committee composed of co-chairmen of the Joint OHSC, the President of the Local Union, the Superintendent Industrial Relations, the Superintendent Environment Services and one (1) other union member of the Joint OHSC shall meet every three (3) months at mutually agreeable times. At such meetings the parties shall deal with recommendations and unresolved matters received from the departmental OHSC's and submit its findings to the President, General Manager.

- (d) The Company agrees to fully cooperate with all OHSC's and will provide them with every reasonable facility for carrying out their inspections and investigations, and access to all reports, plans, and records pertinent to the work of the OHSC's.

- (e) The manager agrees to develop a Mine Health, Safety and Environment program which includes the following sections:
 - i) a written policy, statement;
 - ii) general safety rules;
 - iii) safe working procedures on a departmental basis;
 - iv) a list of hazardous materials, safe handling procedures, and antidotes;
 - v) provisions for regular monthly crew safety meetings;
 - vi) procedures for accident and serious incident investigation; and
 - vii) procedures for safety tour inspections.

- (f) The co-chairmen of the Joint Occupational Health, Safety and Environment Committee or their designates shall accompany an Inspector of Mines during official investigations as per the Mines Act.

11.03

- (a) Department Occupational Health and Safety Committees will be established and

will meet twice each month. The purpose of these committees is to review the ongoing Health, Safety and Environmental Programs, exchanging information and considering specific health, safety and environmental problems at work locations within the departments. The Department Committees shall review the Mine Health and Safety Program for completeness and effectiveness on an ongoing basis and submit its findings to the President, General Manager, and the Co-chairmen of the OHSC.

- (b) The Mine, Mill and Administration Department Committees shall consist of the area representatives from the department and the crew safety representative on shift at the time of the month end meeting and the department manager and two (2) other company designates. The Local Union and the Company shall each designate one (1) member as co-chairman of the Committee.
- (c) The Department Committees shall designate one (1) member selected by and from the Union and one (1) member selected by and from the Company, from each department to form a Departmental Joint Safety Inspection Team. This Inspection Team shall conduct safety inspections once monthly at a mutually agreeable time within the Company's

operations. The Departmental Joint Safety Inspection Team shall report their findings to the Departmental OHSC and the appropriate department head immediately following the inspection.

The Departmental OHSC shall meet, as soon as possible after the inspection, to discuss its findings and any other matters concerning health, safety, or the environment. The co-chairmen shall alternate chairing the meetings.

11.04 Health, Safety and Environment Committee representatives shall be paid their hourly rate as defined in Article 19.08 for time lost during working hours while attending meetings, inspection trips of their committees and accident or dangerous occurrence investigations. Such time will be considered as time worked for the purposes of computation of pay under the overtime provisions of this Agreement.

11.05 For time spent attending to Health, Safety and Environment issues, meetings, tours, accident or dangerous occurrence investigations, and training as required by the Company which require time off work, Safety Committee Representatives shall be paid their hourly rate as defined in Article 19.08. As much as possible the tour and meetings will be scheduled when the majority of the Union Committee is on day

shift. For the date of the tour and meeting the remaining committee members will be **transferred to day shift.**

11.06 The Company will provide minutes of all Health, Safety and Environment Committee meetings within five (5) working days following such meetings, exclusive of Saturdays, Sundays, and recognized holidays.

11.07

- (a) The Company will provide the OHSC and the Department Health, Safety and Environment Committees once a month with a daily and monthly summary of injuries for review and discussion by the Committees. The Company will also provide the Local Union with summaries and copies of all crew safety meeting minutes, first aid reports for the month, Workers' Compensation Board Form 7A's and a list of all employees who the Company is aware have applied for Weekly Indemnity, Workers' Compensation Benefits or are utilizing the Light Duty Program.

- (b) Should the Company request a meeting with an employee to discuss his claim with the Workers' Compensation Board, he will be entitled to a Union representative, with preference given to members of the Union W.C.B. Committee if it can be arranged.

- (c) The Company shall provide the Union with copies of claim related information it submits to the Workers' Compensation Board and the Union shall provide the Company with copies of claim related information it submits to the Workers' Compensation Board.
- (d) Employees will be given a copy of the First Aid Report at the time it is completed by the First Aid Attendant.

11.08

- (a) The Union Co-chairman or his designate and a member of the appropriate Department Health, Safety and Environment Committee, shall be notified immediately in order that he may be accompanied to the site of an accident or dangerous occurrence required to be reported pursuant to the Mines Act, Health, Safety & Reclamation Code.
- (b) The accident or occurrence site shall not be disturbed, except for the purpose of saving life or relieving human suffering, until the employee members referred to in Article 11.08(a) have had the opportunity to inspect and investigate the site, and the Inspector of Mines or the employee member referred to in Article 11.08(a) authorizes such disturbance. (in the event of a fatality the site can only be released by the Chief Inspector of Mines).

11.09 If an employee suffers a fatal accident while at work, the Company shall notify the President of the Local Union in order that he may designate two (2) employees who shall, within sixteen (16) hours of such fatality, be accompanied on an inspection of the accident site and, at the same time, be provided with all available pertinent information concerning the fatality. Each such employee shall be given a leave of absence of one (1) day with pay.

11.10 The Company and the Union agree to cooperate in developing and maintaining a strong sense of safety awareness among employees and supervisors. It is, therefore, recognized that every employee has the right to refuse work if he has reasonable cause to believe that to do so would create undue hazard to the health or safety of any person.

11.11

- (a) An employee who refuses to carry out any work or operate equipment, tool or appliance in compliance with Article 11.10 shall immediately report the circumstances to his supervisor.

- (b) The Supervisor receiving the report shall immediately investigate the matter and ensure that any hazardous condition is remedied without delay, or if in his opinion the report is not valid, he shall inform the employee who made the report.

- (c) If the employee continues **to** refuse to carry out the work, the Supervisor shall make an investigation in the presence of the employee who made the report, together with a Union member of the OHSC, or his designate, and a crew safety representative having knowledge of the work in question.

- (d) If following the investigation set out in 11.11(c) above the matter is still unresolved, the matter shall be referred to the OHSC who, together with the Department Manager, shall investigate and make recommendations to the President, General Manager on a resolution **to** the matter. The President, General Manager shall make a final determination in the matter, subject **to** review by the Ministry of Mines.

- (e) While the matter is under investigation, the employee(s) who refuses to work is entitled to be reassigned alternate work with no **loss** of pay and to return **to** the job in question when it is determined safe to do so. No employee will be required or permitted to perform work, where another employee has refused **to** work, unless the alternate employee in the presence of the Union member of the OHSC has been informed by the supervisor of the reason for the refusal.

- (f) A supervisor shall not knowingly perform or permit a worker **to** perform work which is, or

could create, an undue hazard to the health or safety of any person.

11.12 The Company shall send copies of government report materials to the Union regarding Health, Safety or Environment matters affecting employees at work. These copies will be sent whether initiated by the Company or the Government. The Union shall reciprocate with report material whether initiated by the Union or the Government.

11.13 The Company and the Union agree that the U.S.W.A. Local 7619/H.V.C. Safety Complaint forms will continue to be utilized so that employees can document and register recommendations for approval by the OHSC. Safety complaint forms that first line supervisors are unable to address immediately, shall be responded to in writing within four (4) working days.

11.14 When an employee is injured at work and the examining physician recommends that the employee not return to work he shall be paid at his hourly rate of pay for the remainder of the day on which he was injured. When the examining physician states that the injured employee is able to return to work on the same day, the employee shall be paid his hourly rate of pay for the total time lost as a result of the injury. The Company shall provide any transportation required for employees injured at work, to their

final destination, whether it be a hospital within a sixty (60) mile radius of the mine site or home.

11.15 In the event the Mines Act, Health Safety and Reclamation Code, does not cover a situation, the Industrial Health and Safety Regulations pursuant to the Workers' Compensation Board under the authority of the Workers' Compensation Act or any other applicable legislation shall apply.

11.16

- (a) Having recognized the value of having trained First Aid personnel on the Company property, it being beneficial to the Safety Program, the Company will pay a thirty five (35) cent premium per hour to the holders of an Occupational First Aid Level III Certificate.

- (b) Qualified members of the Emergency Response Team (ERT) will be paid a premium of twenty-five (25) cents per hour. The Company will determine who is qualified and will also establish the number of E.R.T. members on each shift and in each department area.

Qualified members must have:

- i) A valid St. John First Aid Certificate
- ii) A valid Mine Rescue Certificate

- iii) Successful completion of six (6) elements of the Justice Institute of B.C. Level I Fire Fighters Course,

11.17

- (a) The Company shall provide an adequate supply of standard protective safety equipment as required, which shall include:

leather faced work gloves
welding gloves
rubber boots / sockettes
asbestos gloves
high voltage gloves
mono goggles
safety glasses (prescription)
respirators
winter hard hat liners
safety belts
safety face shields
leather aprons
ear protection
aprons and face shields for handling
corrosive substances
surveyor vests
welding jackets
asbestos suits
welding helmets
hot sticks

fresh air packs
knee pads
winter mitts
lead aprons

which shall be made available as determined to be necessary by the employee's foreman. Subsidized payment for protective coveralls shall be made by the Company on the basis of up to twenty-five dollars (\$25.00) per pair to a maximum of four (4) pairs per year and fifty percent (50%) up to fifty dollars (\$50.00) per pair for safety boots. The Company will cover the cost of laundering coveralls on a weekly basis.

(b) The quality of the standard protective safety equipment contained in article 11.17(a) shall be reviewed for effectiveness by the Joint Occupational Health and Safety Committee.

11.18

(a) The Company shall install, maintain in good condition and operate adequate heating and ventilating systems and shall comply with the requirements of all applicable laws.

(b) All lunchrooms to be adequately heated, lighted, supplied with hot and cold running water. Lunchrooms shall to the extent possible be sealed to prevent contaminants and noise from entering and shall be cleaned daily.

- (c) Where it is not practicable **to** provide running tap water, potable drinking water in approved sanitary containers shall **be** provided. Paper cups will be supplied.

11.19

- (a) A logbook shall be provided for and maintained by employees in each unit of mobile equipment over 7,000 kg gross vehicle weight.
- (b) The operator of any equipment shall examine and check the equipment before putting it into use and if an unsafe condition is discovered, he shall:
- (i) note the unsafe condition in the vehicle logbook, and
 - (ii) not operate the equipment until repairs have been made by a qualified person and noted in the logbook, **or**
 - (iii) the qualified person has assured him *it* is not unsafe to operate the vehicle and noted the reason in his logbook.
- (c) If no unsafe condition or problem is experienced, the operator shall also record this in the logbook.
- (d) Prior **to** operating any unit of mobile equipment, the operator shall read any

entries made in the logbook, and, if an unsafe condition has been recorded but not corrected, he shall not operate the equipment until repairs have been made by a qualified person and noted in the logbook, or the qualified person has assured him it is not unsafe to operate the vehicle and has noted the reason in the logbook.

- (e) The Manager shall ensure that the logbook system is working effectively.
- (f) A maintenance record shall be kept of all unsafe conditions reported and the repairs made to each individual piece of mobile equipment to correct unsafe conditions.
- (g) Every notation made in the logbook, maintenance record, and every other record relating to the condition of the equipment shall show the time and date of the entry and the name of the person who made the entry.

11.20 The Company will continue with its Workplace Hazardous Materials Information System (WHMIS) Training Program to ensure that all employees are kept up-to-date with material identification and use.

11.21

- (a) Where an environmental problem exists in the workplace, at the request of either party,

the Joint OHSC shall investigate the problem. Trained members of the Emergency Response Team or the Joint OHSC shall conduct the necessary monitoring to determine the nature or degree of the hazard or potential hazard. Equipment required for such monitoring shall be made available by the Company.

- (b) The Company agrees to train and instruct all members of the Emergency Response Team and the Joint OHSC in the correct use of monitoring equipment and in the techniques of sampling and analysis for potentially toxic substances occurring within the Company's operation. This training will be done within three (3) months of any employee's appointment to the Emergency Response Team or the Joint OHSC.

11.22 The Company shall inform all Contractors of relevant Safety Rules and Procedures and shall ensure such Regulations and Safety Rules are enforced.

ARTICLE 12 - HOURS OF WORK

12.01 This Article is intended to define the normal hours of work and shall not be construed as any guarantee of work or pay of hours of work per day, or per week, or of days of work per week. This Article shall not be considered as any

basis for the calculation or payment of overtime which is covered solely by Article **13**.

12.02 The work day shall commence at the start of the employee's regularly scheduled shift and end twenty-four (**24**) hours later.

12.03 A work week for the purposes of this Article shall consist of seven (7) consecutive days beginning at 8:00 a.m., Friday.

12.04 The regular shift starting time normally shall be **6:30** a.m., **7:00** a.m., **7:30** a.m., **8:00** a.m., **4:00** p.m., **7:00** p.m., **8:00** p.m. and midnight. The Company may schedule any operation, employee or group of employees at other times because of emergencies, breakdowns, or preparation for start-up of work and efficiency of the operation.

12.05 At its discretion, the Company may initiate and maintain continuous and/or semi-continuous operations, subject to the pertinent statutes and regulations of the Province of British Columbia. The Union hereby agrees to jointly apply with the Company to the Director of Employment Standards for approval of such schedules.

12.06 The Company and the Union agree to the following shift schedules:

(a) Eight Hour Shift - Steady Days:

Eight (**8**) hours per day, five (5) days per week, Monday through Friday. The normal hours of work shall be 8:00 a.m. to 4:00 p.m.

(b) Eight Hour Shift - Semi Continuous:

Eight (**8**) hours per day, five (5) days per week, Monday through Friday. The normal hours of work shall be:

- i) Day Shift - 8:00 a.m. to 4:00 p.m.
- ii) Afternoon Shift - 4:00 p.m. to 12:00 a.m.
- iii) Night Shift - 12:00 a.m. to 8:00 a.m.

These shifts shall be rotated at least every two (2) weeks, but the Company may rotate shifts more frequently after having discussed the matter with the Union.

(c) Ten Hour Shift - Steady Days

Ten (10) hrs/day, Forty (40) hrs/week, Monday to Friday

(d) Twelve Hour Shift - Semi Continuous:

Twelve (12) hours per day which is based on a work cycle that is eight (**8**) consecutive weeks (four (**4**) shifts on, four (4) shifts off) averaging forty-two (**42**) hours per week. The normal hours of work shall be 8:00 a.m. until 8:00 p.m.

(e) Twelve Hour Shift - Continuous:

Twelve (12) hours per day which is based on a work cycle that is eight (8) consecutive weeks (four (4) shifts on, four (4) shifts off) averaging forty-two (42) hours per week. The normal hours of work shall be:

- i) 2 Day Shifts of 8:00 a.m. to 8:00 p.m. followed by
 - ii) 2 Night Shifts of 8:00 p.m. to 8:00 a.m.
- (f) The parties to this collective agreement recognize that there are a number of maintenance and service employees currently working on schedules other than those set out in (a), (b), (c), (d) and (e) above. The Company shall determine and notify the Union of the nature of the hours of work and the number of employees affected.

12.07

- (a) Eight (8) hour shift employees shall have a lunch break of thirty (30) minutes normally between the fourth and fifth hour of the shift.
- (b) Twelve (12) hour shift employees shall have two (2) thirty (30) minute lunch breaks normally in the fourth or fifth hour and the eighth or ninth hour of the shift.

12.08

- (a) Supervisors shall arrange that all employees on eight (8) hour shifts shall have reasonable **opportunity for a cup of coffee** during the first (1st) and second (2nd) half of each shift.
- (b) All employees on a twelve (12) hour shift shall be entitled to a ten (10) minute break during each half of the shift.

12.09

- (a) Employees working on continuous multiple shift jobs must not leave their place of work at the end of the shift before their replacement or a qualified replacement for the following shift has reported for work. Such an employee must remain at his place of work for up to one (1) hour.
- (b) Employees who have been replaced shall be free to wash themselves without loss of time after having been replaced before the end of their shift.
- (c) Employees, other than those referred to in (b) above, shall be free to wash themselves ten (10) minutes prior to the end of the shift.

12.10

- (a) Modification of, or new shift schedules, shall be made and posted wherever possible, not later than forty-eight (48) hours preceding the scheduled change. Where less than

forty-eight **(48)** hours notice is given the employee(s) shall report for work and the Company shall pay, by the way of penalty, time and one-half ($1\frac{1}{2}$) for the first shift worked following such change. No employee's regular schedule shall be reduced or interrupted to avoid payment of penalty.

- (b) Shift changes shall not be made to avoid the payment of overtime. When an employee works one of his scheduled days off, he shall not be required to take another day off during his regularly scheduled work week.
- (c) Where a change in a shift schedule causes an employee to take more than his normal days of rest, he may elect to work on such day (including a normal day of rest) provided that;
 - i) work is available, and
 - ii) the performance of that work is approved by the Company in its sole discretion.

When work is performed pursuant to this sub-clause no overtime rates shall apply for regular hours worked and no hours worked shall be used to calculate overtime pay for hours worked in excess of normal hours worked on such days.

- (d) Employees, who are assigned to the compressed work week from schedules which require eight (8) hours of work per day, shall be paid at time and one half for the hours worked in excess of forty (40) hours in the first work week in which the compressed schedule is worked.

12.11 Days off shall be scheduled consecutively.

12.12 Overtime work shall be voluntary except for work of an emergency nature and as provided for in Article 12.09 (a).

12.13 The Company shall, if necessary, provide transportation for an employee who is required to work overtime pursuant to Articles 12.09 (a) or 12.12.

12.14

- (a) An employee working more than two (2) hours of overtime beyond his regular scheduled shift is entitled to a thirty (30) minute paid lunch break and a hot dinner, or \$10.00 in lieu of the dinner after two hours of overtime. An additional thirty (30) minute lunch period will be granted four (4) hours later.
- (b) No lunch will be provided after the second lunch period.

12.15 The Union recognizes that lunch time scheduling will be required to accommodate blasting and servicing of equipment.

ARTICLE 13 - OVERTIME AND SPECIAL PAY

13.01 The work day for the purposes of this Article shall be defined as the twenty-four (24) hour period commencing at the start of the employee's regularly scheduled shift and ending twenty-four (24) hours later.

13.02

- (a) The hours for which a paid holiday allowance is paid as provided in Article 14, shall be deemed to be hours worked in computing overtime on a weekly basis, provided the employee was normally scheduled to work such hours.

- (b) Days in lieu shall not be considered as time worked for the purpose of computing overtime on a weekly basis but will be considered as time worked in the calculation of built in overtime.

13.03

- (a) Eight Hour Shift

One and one half (1 1/2) times the employee's regular hourly rate shall be paid for:

- i) time worked in excess of eight (8) hours in any twenty-four (24) hour period.
- ii) **time worked in excess of forty (40) hours in a work week.**
- iii) time worked on the employee's first scheduled day of rest.

Two (2) times the employee's regular hourly rate shall be paid for:

- i) time worked in excess of ten (10) hours in any twenty-four (24) hour period.
- ii) time worked in excess of forty-eight (48) hours per week.
- iii) all hours worked on an employee's second scheduled day of rest.

(b) Twelve Hour Shift

One and one half (1 1/2) times the employee's regular hourly rate shall be paid for:

- i) time worked in excess of forty-four (44) hours per week.
- ii) for the first eight (8) hours worked on scheduled rest days.

Two (2) times the employee's regular hourly rate shall be paid for:

- i) time worked in excess of twelve **(12)** hours in twenty-four **(24)** hour period.

- ii) time worked in excess of forty-eight **(48)** hours in a week.

13.04 The Company shall pay an employee requested to work overtime at the applicable overtime rate for a minimum of one (1) hour or for actual hours worked whichever is greater. The one (1) hour provision shall not apply to employees continuing work in compliance with Article 12, Sub-section 12.09 (a) or those employees who are transported to and from their workplace on Company time. Payment to the nearest one tenth of one hour will be made in these cases.

13.05 No overtime shall be paid for hours worked in excess of the employee's regularly scheduled hours in a work day because of personal arrangements between employees. Any such arrangements must be made with the express permission of the employee's foreman.

13.06 In the payment of overtime as defined in this Article, the one basis which results in the payment of the largest amount of overtime shall be used. There shall be no pyramiding of overtime.

13.07 Where an employee who reports for work for his regular shift and who has not been

notified not to report to work (except an employee returning from an unauthorized absence):

- (a) is sent home because no work of any kind is available, he shall be paid an amount equal to four (4) hours pay at his hourly wage rate.
- (b) is offered alternate work, the Company shall not pay a penalty. However, the employee may choose to refuse alternate work and go home without pay or discipline for that shift.

13.08 An employee who has already left the Company's premises after the end of his regular shift and is called out to work, shall be paid the applicable overtime rate for each hour worked, from the time he reported for work on call-out to the starting time of his next regular shift, but in any event, he shall be paid not less than the equivalent of three (3) hours at the double (2) time rate.

13.09 Shift premiums shall be paid for regularly scheduled hours worked as follows:

- i) a premium of thirty-five (35) cents per hour for shifts commencing on or after 2:00 p.m., but before 10:00 p.m.
- ii) a premium of forty (40) cents per hour for shifts commencing on or after 10:00 p.m., but before 6:00 a.m.

13.10

- (a) Employees employed on four **(4)** day continuous shift rotating schedules shall be paid a shift premium of sixty (60) cents per hour for all hours worked.
- (b) Employees employed on four **(4)** day semi-continuous shift shall be paid a shift premium of fifteen (15) cents per hour for all hours worked.
- (c) No shift premiums shall be paid for shifts commencing on or after 6:00 a.m., but before 2:00 p.m., except as described in Sub-section 13.10 (b).
- (d) Shift premiums shall not apply where an overtime rate is being paid, except as described in Sub-section 13.10 (a).

13.11 The Company shall pay a premium of one dollar and fifty cents (\$1.50) per hour for all scheduled work performed during the forty-eight **(48)** hour period following 8:00 a.m., Saturday.

13.12

- (a) Overtime shall be distributed as equitably as circumstances permit and compatible with efficient and economic operations of the Company among the qualified employees in the appropriate occupational groups within the department. **An** employee declining to work overtime shall be deemed to have

worked in the recording of overtime distribution among the qualified employees. Any employee with the permission of his foreman may examine the overtime records of all employees in his wage classification in his department. Such permission by the foreman shall not be unreasonably withheld. The Company shall post a list of the previous weeks overtime activity (except overtime which results from regular shift scheduling) on the appropriate bulletin boards. After the posting of the previous weeks overtime list, the chief shop steward and general foreman in each department shall discuss the allocation of overtime in the preceding week, and attempt to resolve any inequities which may have occurred.

- (b) Provided there is mutual agreement, the parties in any department or occupational group within a department may arrange another method of overtime distribution which shall apply in place of (a) above.
- (c) Employees are not eligible for overtime while they are away from work on regular or special vacation, except in the case of an emergency. This includes regularly scheduled days off immediately prior to the first scheduled vacation day, the scheduled days off during the vacation period and the scheduled days off prior to the first scheduled day back at work.

In the event all qualified employees in the appropriate occupational groups within the department have declined to work overtime, then the Company may offer the overtime to the employee on vacation.

13.13

- (a) The following shall apply regarding the shift change in Mine Operations:
- i) Where Company transportation is provided, it will leave the Dry at a quarter (1/4) to the hour.
 - ii) A premium of \$15.00 per shift worked will be paid to those employees leaving the Dry at a quarter (1/4) to the hour.
 - iii) The premium is meant as payment to the employee such that he is classified as working when he leaves the Dry and will begin his assignment immediately upon arrival at his piece of equipment.
 - iv) Operators will be picked up at the work station, and the Company will transport them to the Dry as close to the hour as possible. It is recognized that due to inclement weather or mechanical failure of the bus it may not be possible to have the employees at the Dry on the hour. Where employees arrive at the Dry more than ten (10) minutes after the

hour, the Company will pay a penalty of one-half (1/2) hour at two (2) times the employee's regular hourly rate.

- (b) The Parties agree that in those instances where emergency work on a continuous shift basis is required, the employees performing the work will work a hot change schedule.

13.14 Those employees working the continuous shift schedule in mill operations who are required to relieve at their workstation will be paid one tenth (1/10) of an hour overtime, except for the crusher operators who already receive a premium.

ARTICLE 14 - PAID HOLIDAYS

14.01 The following days shall be paid holidays: New Year's Day; Good Friday; Victoria Day; Canada Day; B.C. Day (first Monday in August); Labour Day; Remembrance Day; Thanksgiving Day; Christmas Day; Boxing Day; Employee's Floating Holidays, as provided by Section 14.07.

14.02

- (a) An employee shall be paid a holiday allowance of eight (8) hours at his regular hourly rate for each of these holidays, provided he has complied with the provisions of Section 14.03. Statutory

Holidays shall begin at 8:00 a.m. on the day of the holiday and terminate at 8:00 a.m. the following day.

- (b) Employees on a 4 x 4 schedule who are scheduled to work on a statutory holiday and subsequently instructed not to work that day shall be paid for twelve (12) hours at their basic rate.
- (c) Those employees assigned to temporary positions which are paid at a higher rate of pay shall be paid at the rate of the position to which they were temporarily assigned provided they meet the requirements of 14.03(b).

14.03

- (a) Except if he is on his vacation, to be entitled to the holiday allowance, an employee must meet both of the following conditions:
- (b) Work throughout his last scheduled shift immediately preceding the paid holiday and his first scheduled shift immediately following the paid holiday, and on the holiday if scheduled, unless he was absent with leave, or laid off, or unless he satisfies the Company that his absence was due to illness or injury.
- (c) Perform work within the ten (10) calendar day period immediately preceding the day

on which the holiday is observed or within the ten (10) calendar day period immediately following the day on which the holiday is observed.

14.04

- (a) If a paid holiday falls within an employee's vacation period, the employee shall receive his holiday allowance in addition to his vacation pay and, **at** the employee's request, he may be scheduled off for an additional day immediately prior *to* or following the employee's vacation unless such day off interferes with the efficient operation of the Department. In this event, the day off shall be re-scheduled at a mutually convenient time.

- (b) Where a statutory holiday is observed on an employee's scheduled day of rest, the employee may elect to take a substitute day off without pay at a mutually time, unused days in lieu will be cancelled one year from the day earned.

14.05

- (a) An employee required **to** work on a paid holiday, provided he is entitled **to** a holiday allowance, shall be paid **two** (2) times his basic hourly rate for hours worked, in addition to his holiday allowance, up **to** and including eight (8) hours. All hours worked in excess of eight (8) hours shall be paid at

three (3) times the employee's basic hourly rate.

- (b) 4 x 4 employees working on a statutory holiday will be paid double time for the first twelve (12) hours in addition to his holiday allowance up to and including eight (8) hours. ($2 \times 12 + 8 = 32$ hours).
- (c) Time worked on statutory holidays shall be distributed as equitably as circumstances permit and compatible with efficient and economic operations of the Company among the qualified employees in the appropriate occupational groups within the department. An employee declining to work a statutory holiday shall be deemed to have worked in recording of time worked on statutory holiday distribution among the qualified employees. Any employee with the permission of his foreman may examine the statutory records of all employees in his occupational group in his department. Such permission by the foreman shall not be unreasonably withheld. The Company shall post a list of the previous time worked on statutory holidays on the appropriate bulletin board following the statutory holiday. After the posting of the previous statutory holiday list, the Chief Shop Steward and general foremen in each department shall discuss the allocation of time worked on statutory holidays on the preceding

statutory holiday and attempt to resolve any inequities which may have occurred.

- (d) Provided there is mutual agreement, the parties in any department or occupational group within a department may arrange another method of distribution of time worked on statutory holidays which shall apply in place of (c) above.

14.06 If another day is substituted by Federal or Provincial statute, or agreement between the parties for the observance of a holiday, the day of observance so substituted shall be deemed to be the holiday for the purposes of this Article.

14.07

- (a) An employee will be entitled to one Floating holiday for each six (6) months of continuous service. Floating holidays will be scheduled on an individual basis by mutual agreement between the employee and his Supervisor, Payment for Floating Holidays will be equal to the number of hours the employee would normally have worked on the day floater is taken. Employees may bank Floating Holidays up to a maximum of twenty-four (24) hours.
- (b) On crews with six or more employees, and where vacation requests have completely taken up the maximum number of employees allowed off on vacation, the Company will

allow a minimum of one extra employee off for the purpose of either floaters or days-in lieu. In doing so, employees will be allowed to group floaters and days-in-lieu which will be granted on a first come first served basis.

ARTICLE 15 -WAGES

15.01 The Company agrees to pay and the Union agrees to accept the job classifications and the hourly wage rates set forth in Appendix " A which is attached to and forms part of this Agreement.

15.02

(a) An employee who is temporarily transferred from his regular job shall be paid the wage rate of the job to which he has been transferred, provided such rate is not less than that of his regular job. If the rate of the job to which he is temporarily transferred is less than the rate of his regular job, he shall be paid his regular rate during the period of such temporary transfer. However, if such employee is allowed to exercise his seniority rights in accordance with Article 9, he shall be paid the rate of the job to which he transferred or assigned. Rate changes shall apply only when job changes have a duration of an hour or more and the employee shall be paid the higher rate for the entire shift.

- (b) In the case of office and technical positions, an employee who is temporarily transferred from his regular job to a different job will be paid the higher rate of either the new job or the rate of his regular job, provided he has the academic qualifications to fill the new job as set out in the wage qualifications section of the collective agreement.

15.03

- (a) If any new job classifications are established or if there is a substantial change in the job content on any job classification set forth in Appendix "A" or if any job classifications have been overlooked in Appendix "A" the parties agree to meet and negotiate a rate of pay for the job(s) in question and where required establish a suitable job title.
- (b) If the parties are unable to reach agreement on a dispute as to whether or not there is a substantial change in job content or the rate of pay for a new or changed job, the dispute shall be settled by arbitration.
- (c) Except as provided above, no basis shall exist for an employee to allege that a wage rate inequity exists, and no grievance on behalf of an employee alleging a wage rate inequity shall be filed or processed during the term of this Agreement.

ARTICLE 16 -VACATIONWITH PAY

16.01 For the purpose of this Article anniversary dates for vacation entitlement will be the employee's date of hire.

16.02

(a) Employees will be granted vacation as follows:

<u>Completed Years of Service</u>	<u>Working Hours Entitlement</u>	<u>Pay %</u>
6 months but less than 1 year	40	4.0
1 or more but less than 2 years	80	4.2
2 or more but less than 6 years	120	6.0
6 or more but less than 8 years	128	6.4
8 or more but less than 10 years	160	8.0
10 or more but less than 12 years	168	8.4
12 or more but less than 15 years	176	8.8
15 or more but less than 18 years	184	9.2
18 or more but less than 25 years	200	10.0
25 or more	224	11.2

An employee with one (1) or more years of service but less than two (2) years of service on his anniversary date is entitled to 80 hours of vacation less the 40 hours of vacation granted to him when he completed six (6) months of service.

- (b) An employee may elect to take the appropriate percentage his pay, or his regular rate of pay for the duration of his vacation period, whichever is greater.

16.03

- (a) Operational requirements shall govern vacation schedules, but preference shall be given to employees in accordance with seniority where requested vacation periods conflict. Departmental vacation schedules shall be posted by April 25th of each year, but shall be subject to changes made necessary by operational emergencies or personal requests. The Company shall advise employees affected by any changes as far in advance as possible.
- (b) Upon receipt of proof of **loss** the Company shall reimburse an employee all money lost as a result of his vacation being rescheduled by the Company, provided the employee has made arrangements through his Supervisor to have vacation time off and makes the Supervisor aware, in writing at the time the vacation is rescheduled. of the

financial loss the employee will incur as a result of the rescheduling.

- (c) On or after March 1st of each year employees will be called upon to indicate preference in vacation scheduling. Those employees indicating preference for vacation time before 11:59 p.m. on March 31st of each year will be given preference in order of seniority. Employees electing to split their vacation will be entitled to preference for only one portion of vacation. This process shall repeat itself until all vacations are completed.
- (d) Those employees who do not indicate preference for vacation scheduling by 11:59 p.m. on March 31st of each year will take their vacation in vacation blocks which are not already filled. The Company shall retain the right to schedule those vacations, provided that the Company will *not* schedule vacation in prime time.

16.04

- (a) Employees will be provided with an itemized cheque for Vacation pay on the pay period ending as close to their anniversary date as possible, but no later than anniversary date. Employees entitled to the special vacation allowance under Article 16.09 will be paid their allowance in the same manner as specified for vacation pay except in the case

of the first special vacation period in which case the payment will be held until the anniversary date of the employee.

- (b) A separate pay cheque or statement will be generated for payment of these vacation allowances and will be distributed in the same manner as the pay cheque or statement.
- (c) In the event that an employee's special vacation is not scheduled during a five (5) year qualifying period, the employee will forfeit the right to take the one hundred and twenty (120) hours of time off.
- (d) Upon termination an employee is entitled to the higher vacation percentage or pro-rated hours at their regular rate. Pro-rated hours will be calculated by multiplying the hourly entitlement times the fraction determined by dividing the calendar days, since the last anniversary date, by three hundred and sixty-five (365) and rounding up the next whole hour. This calculation will be done on last anniversary date entitlement.
- (e) Until an employee has completed five (5) years of service there is no entitlement under the special vacation provisions of the Collective Agreement.

16.05 Since the purpose of vacation is rest and recreation, employees will, except in extra-

ordinary circumstances beyond the employee's control, be required to take not less than the vacation entitlement set out in the Employment Standards Act appropriate to their years of service.

16.06 Employees who leave the service of the Company shall be paid at the time of severance in accordance with the provisions of this Article.

16.07 Vacations may be split into units in accordance with an employee's shift cycle. Vacations shall not be taken in blocks less than one shift cycle, except where there is less than one shift cycle remaining in vacation entitlement.

16.08 The Company shall pay one dollar and fifty cents (**\$1.50**) per hour for each hour of vacation.

16.09 A Special Vacation Program has been instituted for employees with more than five (5) years of service. Those employees who have completed five (5) or more years of service shall be entitled to a Special Vacation of one hundred and twenty (120) hours in addition to their normal entitlement to be taken within the period of five (5) years calculated from his most recent anniversary date. During each subsequent five (5) year qualifying period, those employees shall become eligible for a further one hundred and twenty (**120**) hours of Special Vacation.

16.10 Special Vacations shall be governed by the following conditions:

- (a) **they shall be taken at times which are** suitable to both the Company and the employees.
- (b) the allocation of regular vacations with pay shall have priority over the allocation of Special Vacations.
- (c) in the event that an employee's Special Vacation is not scheduled during the five year period that follows his qualification for special vacation pay, he forfeits his entitlement to this vacation time.
- (d) an employee who retires shall be entitled to a payment equivalent to a full one hundred and twenty (120) hours of Special Vacation pay provided he has worked a minimum of 50 percent (50%) of the available time or 480 hours, whichever is the lesser, during the qualifying period.
- (e) if an employee leaves the service of the Company or his employment is terminated during any five (5) year qualifying period, he shall be paid a sum proportionate to the service he has completed in the qualifying period. Should such an employee be rehired, upon completion of this qualifying period he will be eligible to receive one

hundred and twenty (120) hours Special Vacation. However, his vacation pay shall be computed on the basis of the balance of the qualifying period for which he has already received a proportionate payment.

- (f) absence by an employee during a five (5) year qualifying period due to sickness or accident up to a total of twelve (12) months shall not affect his Special Vacation benefits. That portion of absence due to sickness or non-compensable accident which is in excess of twelve (12) months shall result in a pro-rata reduction in Special Vacation pay.

Time spent on vacation for which the employee is paid under this Article shall be considered as time worked for purposes of this sub-section but absences for any other reasons during a qualifying period shall result in a pro-rata reduction in Special Vacation pay. The time allowed for Special Vacation shall not be reduced.

- (g) no employee shall receive more than one hundred and twenty (120) hours Special Vacation during any five year period following the date of qualification.
- (h) Special Vacation pay will be calculated in accordance with the provisions of this Article in the same manner as regular vacation pay is calculated as set out in Article 16.02.

16.11 The payment of special vacation and/or vacation pay on or near the anniversary date constitutes the Company's full payment. No further payment will be made, even though an employee's rate may change between the time of payment (anniversary date) and the time they take the vacation.

ARTICLE 17 - LEAVE OF ABSENCE

17.01

- (a) Employees may be granted leaves of absence without pay for sufficient reason at the discretion of the Company. A leave of absence permit must be in writing and signed by an authorized Company official. A copy of this absence permit will be issued to the employee, in a timely fashion.

- (b) The Company may, at its discretion, grant reasonable leave of absence to an employee for educational or training purposes, conditional but not limited to the following:
 - i) that the employee apply at least one (1) month in advance unless grounds for such application could not reasonably be foreseen.

 - ii) all such leaves of absence shall be approved by the President, General Manager.

- (c) The Company shall grant Leave of Absence for up to twelve (12) employees for each requested Leave to attend Union Conventions or to do other similar work for the Union, provided the Company is given at least one (1) week's notice in writing and their Absence does not interfere with operations and the Leave shall not exceed two (2) weeks in each case.
- (d) The Company shall grant not more than three (3) employees a Leave of Absence for one (1) year to work in an official capacity for the Local or International Union, without loss of seniority rights. On return from such absence, the employee(s) shall be returned to the wage grade held immediately prior to the Leave, provided a vacancy exists, otherwise, the employee(s) shall be entitled to apply for any existing vacancy in accordance with Article 9, and shall be paid at the rate of the wage grade held immediately prior to the Leave. In addition, he shall be given preference subject to the requirements of the operation, in receiving training, that, except for such Leave, he would be entitled to by seniority.

The employee(s) and the Union must request the Leave. The Leave shall be extended for additional one (1) year periods for Local Representatives and is limited to

three (3) consecutive one (1) year extensions for International Representatives.

- (e) **Leave of absence on a casual basis may be granted to members of the Union selected to do work for the Union, such as negotiations and the preparation and presentation of Workers' Compensation Appeals, if requested by the Union.**
- (f) Where an employee is entitled to, and takes, a vacation as contemplated by Article 16, and upon his return would be required to work up to 3 shifts followed by regularly scheduled days off; he shall be granted unpaid leave of absence for the said shifts required to be worked. In order to qualify for such leave, an employee to whom this Sub-section applies shall make application for leave pursuant to Article 17.04 concurrently with his application pursuant to Article 16.03.
- (g) Where spouses employed by the Company are entitled to joint vacations, but of different duration, the Company shall grant unpaid leave of absence, not exceeding (1) shift cycle, to the spouse with the shorter vacation, provided that the leave does not interfere with a senior employee's vacation entitlement.

17.02 In the Case of a death in the immediate family of an employee, the Company shall grant

the employee a leave of absence for one (1) day. If he attends the funeral of the deceased, an additional three (3) days leave of absence may be granted. The immediate family shall mean the employee's mother, father, stepmother, stepfather, spouse, children, stepchildren, brothers, sisters, grandparents, grandchildren and spouse's brothers, spouse's sisters, mother-in-law, father-in-law, daughter-in-law and son-in-law. The days referred to above shall be exclusive of regularly scheduled days off and the employee shall receive his hourly rate as defined in Article 19, Sub-section 19.08 to a maximum of thirty-two (32) hours pay. Common-law relationships will be recognized as above.

17.03 An employee subpoenaed for jury or witness duty shall be granted a leave of absence for such duties provided that the Company is properly notified in advance of the intended absence. The Company shall pay the difference between the fee paid by the Court for such duties, and the actual hours lost from the employee's regular scheduled shift at his hourly rate as defined in Article 19, Sub-section 19.08. The employee shall be required to furnish proof of jury or witness service and the pay received for such service.

17.04 All applications for leave of absence, and approval of same, made pursuant to this Article, shall be in writing.

17.05

- (a) A Leave of Absence will be granted for an employee who *is* taking any course which would benefit the Company and who is required to take an exam or test during regular working hours.

Where;

- i) An employee has applied for and has received approval for enrollment in a course for which the Company is prepared to pay the cost upon successful completion, and;
 - ii) The employee upon giving reasonable notice has applied for Leave of Absence to submit to required written or oral tests during regular working hours, the Company shall grant a Leave of Absence for that purpose.
- (b) The Company shall pay for the time lost to write the following examinations:
- 1) Trades Qualification Examinations
 - 2) First Aid Qualifications
 - 3) Recognized Accounting Courses
 - 4) Air Brake Endorsements
 - 5) Ambulance Driver Qualifications
 - 6) Any other courses that require an examination that the Company and the Union agree to.

- (c) Employees who are required to write an exam for a course to advance in their line of progression, and such exam falls on a scheduled day of rest, will be paid eight (8) hours at their regular rate of pay.

17.06 Upon reasonable prior notice in writing, the Company will grant any employee an unpaid leave of absence for the first term of office as a Member of Parliament of Canada or as a Member of the Legislative Assembly of British Columbia.

17.07

- (a) Employees shall be entitled to Pregnancy and Parental leave in accordance with the provisions of the Employment Standards Act. Such employees shall not lose seniority because of this leave and shall be restored to their former or equivalent position. Additional Leave of Absence may be granted under Article 17.07 (b) provided the appropriate medical certificates are provided for the dependent on request.
- (b) Notwithstanding the preceding and upon mutual agreement of the Company and the Union, the times referred to in this article may be altered.
- (c) On advice of her doctor, a pregnant employee who requests a transfer to an alternate workplace due to workplace

conditions will be provided with alternative work if available.

17.08 Company recognizes that a request for Parental Leave is a legitimate reason for Leave of Absence, as provided for in Article 17.01 (a).

ARTICLE 18 - INSURANCE BENEFITS

18.01 The Company agrees to pay the full cost of providing the benefits set out below for any employee who has elected or in the future may elect to be covered by the Plans; provided that such employee meets the eligibility requirements for enrolment:

- (a) The Medical Services Plan of British Columbia and the Extended Health Benefit Plan of the Pacific Blue Cross of British Columbia. Effective October 1, 2003, the Extended Health Benefit will be increased from \$25,000 to \$50,000.
- (b) The Basic Dental Insurance Plan "A" provided by Pacific Blue Cross. The Plan shall provide one hundred percent (100%) of basic service claims.
- (c) The Basic Dental Insurance Plan "B" provided by the Pacific Blue Cross. The Plan provides for payment of eighty-five percent (85%) of claims respecting prosthetic appliances, crown and bridge procedures as therein set out.

- (d) The Dental Insurance Plan "C" provided by the Pacific Blue Cross. The plan provides for the payment of fifty percent (50%) of the claims for orthodontal services to a lifetime maximum of two thousand dollars (\$2,000) per family member. The plan will take effect on the date of ratification of the Collective Agreement.
- (e) A Group Life insurance Benefit of \$50,000 for the term of this Agreement commencing on the date of ratification of the Collective Agreement.
- (f) A non-occupational Accident, Death and Benefit (A.D.&D.) of \$50,000 for the term of this Agreement commencing on the date of ratification of the Collective Agreement.
- (g) Employees may opt to purchase through payroll deduction an equivalent Group Life Insurance and/or A.D.&D. benefit at age related rates.
- (h) A Weekly Indemnity Benefit for sickness and non-occupational accident insurance providing payment of sixty-six and two thirds percent (66 2/3%) of the maximum insurable benefits established by the Unemployment insurance Commission. The minimum benefits payable per week are as follows:

- i) April 27th, 1994 \$550 per week
- ii) October 1, 1995 \$575 per week
- iii) October 1, 1996 \$600 per week

Such benefit is provided from the first (1st) day of accident and fourth (4th) scheduled working day of sickness for fifty-two (52) weeks.

(i) **A** Long Term Disability benefit for employees who suffer an illness or non-occupational injury commencing upon the expiration of Weekly Indemnity payments and continuing until recovery, retirement or death. Benefit payments shall be calculated as follows:

- i) For an employee who suffers an illness or non-occupational injury on or after October 1, 1995, the difference between fourteen hundred dollars (\$1400.00) per month and the total of all payments made by government (calculated monthly) to such disabled employees.
- ii) For an employee who suffers an illness or non-occupational injury on or after October 1, 2003, the difference between fifteen hundred dollars (\$1500.00) per month and the total of all payments made by government

(calculated monthly) to such disabled employees.

- (j) Employees may opt to purchase through payroll deductions a matching long-term disability benefit.
- (k) The Company will continue to provide the non-contributory defined benefit pension plan, the terms and conditions of which are found in the "Highland Valley Copper Pension Plan for Hourly Paid Employees represented by the United Steelworkers of America (Local 7619)" which is incorporated into and forms part of this collective agreement.

In the event that the parties agree to amend the pension plan, the amending memorandum of agreement shall become effective upon ratification of the collective agreement by the parties, and such changes will be incorporated into and form part of the pension plan.

The following is a summary of the major pension benefits:

Eligibility and membership

An employee becomes a member on date of hire.

Basic benefit rate:

Effective October 1, 2003

\$52 per month per year of service.

Effective October 1, 2004

\$53 per month per year of service.

Effective October 1, 2005

\$54 per month per year of service.

Unreduced early retirement

Eligibility:

age 58 and total of age plus service at least
84 years

Supplement to age 65

Effective October 1, 1995

\$25 per month per year of service, to a
maximum of 30 years.

Reduced early retirement

Age 55 with 20 years of service

basic pension reduced by 0.5% per month
to unreduced early retirement date plus
supplement to age 65 for service to
retirement date, reduced for early retirement
by 0.5% per month to unreduced early
retirement date.

Age 55 with 10 years of service

basic pension reduced by 0.5% per month
to age 65.

Termination Benefits -vesting
2 years of service.

Survivor's benefits

After retirement

50% of basic pension to spouse, or 60% of the actuarially reduced basic pension as set out in the B. C. Pension Benefits Standards Act.

Before Retirement,with Spouse

Eligibility

Either 15 years service or 60 "points" (total of age plus service) plus 10 years service.

Amount

50% of accrued basic pension (unreduced) to spouse.

Before Retirement, no Spouse

100% of commuted value of vested pension.

Portability

Terminated members, surviving spouses, beneficiaries may transfer value of vested benefits to a locked-in RRSP.

Long Term Disability

Pensionable service continues to accrue on total disability.

- (l) A Plan to provide for reimbursement for basic B.C. Hospital Co-Insurance charged from time to time (currently set at \$8.50 per day) incurred by Bargaining unit employees.

18.02

- (a) The Company shall supply to the Union copies of the master Agreements to all benefit plans agreed to in this Collective Agreement.
- (b) The Company and the employees agree at all times to comply with the policies and regulations of the insurance carriers for benefit plans agreed to in the Collective Agreement.

18.03 Eligibility for benefits under the Plan are as follows:

Medical Services Association Benefits - a transfer from participatory plan is effective immediately. Coverage for new applicants shall become effective in accordance with the eligibility requirements for enrolment in the Plans.

18.04

- (a) The Company shall provide an Optical Plan which provides for a payment of two hundred dollars (\$200) on claims each twenty-four (24) months.

- (b) The Company shall continue the safety glasses program instituted during 1972, wherein it agreed to initially provide glasses for all employees. Under this program, the Company agrees to provide prescription glasses to those employees who require them and to replace glasses upon proof of prescription change or damage.

18.05 The Company will pay Insurance premiums beginning the first (1st) of the month following the month of employment.

ARTICLE 19 - GENERAL PROVISIONS

19.01

- (a) It is understood that no payment shall be made by the Company under Article 11, Section 11.14 if the injured employee receives payment from the Worker's Compensation Board for the time lost.
- (b) To ensure that employees receive Weekly Indemnity Insurance benefits and Workers' Compensation benefits with a minimum of delay, the Company will advance, upon request of the employee, an amount equal to the amount of Weekly Indemnity benefit payable for each benefit entitlement period. Payment of the advance will be made during the week of the request provided that:

- i) the employee cooperates in completing the necessary documents to support his claims.
- ii) the employee agrees to reimburse the Company for any monies so advanced.
- iii) ten (10) days have elapsed since the date the employee filed his completed application for benefits.
- iv) in any event, the Company will not advance money in excess of the vacation pay entitlement due to the employee, where the facts related to the claim are in dispute.

19.02 An employee terminating his employment or being laid off shall be paid all wages due him as promptly as possible.

19.03 Any notice required to be given to the Company under the terms of this Agreement shall be given by registered mail addressed to Highland Valley Copper, P. O. Box 1500, Logan Lake, B. C., VOK 1W0. Any notice to be given to the Union under the terms of this Agreement shall be given by registered mail addressed to the Secretary of the Union at its registered address for Local 7619 at Box 5, Logan Lake, B.C., VOK 1W0 with a copy to the International Union. When either party changes its address, it shall notify the other.

19.04 If one or more representatives of the International Union wish to speak to Local Union officials in the plant concerning a grievance or other official business of the Union, they shall obtain permission from the Industrial Relations and Personnel Department. Such permission shall not be unreasonably withheld.

19.05 The parties agree to exclude the operation of Section 50 (2), (3) and Section 87 of the Labour Relations Code of British Columbia.

19.06 The Company shall install and maintain lights and standard car plug-ins in designated permanent parking areas.

19.07

- (a) Employees will receive their pay by direct deposit to their account at the bank of their choice subject to conditions established by the bank.

- (b) The Company agrees to institute a payroll deduction system to allow employees to contribute to the Steelworkers District Three Savings Plan.

This plan will be for Tax Sheltered funds only. Employees may contribute a percentage of the total earnings or a standard amount per pay period. An employee may change their contribution level in March of each year.

19.08 For the purpose of Sections 5.01 (b), 7.02, 7.03, 8.03, 11.04, 11.05, 11.09, 11.11, 11.16, 17.02 and 17.03, "hourly rate" means the sum of:

- i) the classified rate for work,
- ii) the applicable shift premiums,
- iii) the applicable overtime rates,
- iv) the applicable special pay that would have been in effect at the time of the employee's absence from work.

19.09

(a) The Company agrees to provide a tool allowance for tradesmen as follows:

<u>Tool Allowance</u>	<u>Per Hour</u>
Machinist	.75
Millwright	.75
Heavy Duty Mechanic	.75
Gas Mechanic	.75
Electrician	.70
Instrument Technician	.70
Pipefitter/Plumber	.70
Welder	.65
Carpenter	.65
Tireman	.65

Lube Journeyman	.75
Heat Vent and Refrigeration Mechanic	.70

Apprentices and uncertified trades shall be entitled to the daily tool allowance paid to the journeymen in their trade classification.

- (b) The Company shall replace employee owned tools which are rendered useless as a result of breakage in Company service. The provisions of this Sub-section only apply to employees not otherwise compensated under Sub-section 19.09(a).
- (c) Tool boxes damaged beyond repair through legitimate accidents proven to be no fault of the owner will be replaced by the Company, to a comparable standard, at no cost to the employee.

19.10 On the advise of a qualified medical physician, employees who have been unable to find a job placement under 10.13 may be offered permanent Light Duty accommodations. The nature of these accommodations will be designed having in mind the employee's present physical capabilities, and his present skills and abilities as identified by an Independent Medical Evaluation. The Modified Work committee will research and agree to an appropriate service provider when required.

Members of the Modified Work Committee may recommend candidates for permanent Light Duty accommodations, and the nature of the work to be offered, but the company shall have the right to place such employees who have agreed to Light Duty placements and to promote and demote such individuals and direct their efforts from time to time, free from any limitations provided for in Article 9 of this Collective Agreement provided, however, that the employment of any such individual shall not affect the seniority nor result in the demotion of any other employee.

19.11

- (a) An employee will have the right, upon request to view his personal file.

- (b) After reviewing his file, an employee will be provided, upon request, a copy of any documents on file.

19.12 The Company shall print the Collective Agreement, Benefit Package Booklet and Pension Summary and shall provide each employee with a copy not later than three (3) months after the signing of this Agreement. Extra copies will be supplied to the Union upon request.

19.13 The Company undertakes to give at least one (1) month's notice to each employee required by statute to take a medical

examination or hearing test. Those employees scheduled for hearing tests will take the test on their own time. The cost of Company required medical examinations shall be borne by the Company and arranged during the employee's normal shift with no loss of wages.

19.14

- (a) Should the company request a meeting with an employee to discuss his claim for Weekly Indemnity or Long Term Disability coverage, he will be entitled to a union representative from the members of the Union WCB and Benefits Committee.

- (b) The company shall provide the employee with a copy of all claims related information it submits to the insurance carriers for the Weekly Indemnity and Long Term Disability Benefits programs and if authorized by the employee, shall also provide a copy to the union. The union shall if authorized by the employee, provide the company with a copy of all claims related information it submits to the insurance carriers for the Weekly Indemnity and Long Term Disability benefits programs.

ARTICLE 20 -TRADES ASSIGNMENT

20.01 The Company shall schedule Trades work so that it is performed by those Trade groups which have performed that work

previously at Highland Valley Copper. Every employee shall fulfill the normal regular duties associated with their job, provided that every employee shall perform whatever work of which they are capable.

20.02 There is established a Joint Trades Committee composed of four (4) representatives of the Union and four (4) representatives of the Company; the Committee shall include supervisors and tradesmen familiar with and experienced in trades work.

20.03 The terms of reference of the Committee shall be:

- (a) To investigate and study:
 - i) The performance of trades work;
 - ii) Trades assignments, Trades work overlap;
 - iii) Trades work and trades assignments as they relate to work performed at the operation defined in Article 20.01. With the goal of making the fullest possible use of the qualifications of each tradesman.
- (b) To make recommendations to the Manager, Human Resources and the President of U.S.W.A., Local 7619 respecting the matters set out in (a) above.

- (c) The Committee shall meet at least once each month.

20.04

- (a) Where an employee feels that he has been improperly assigned to perform a job under Article 20.01 or where an employee feels that he should have been assigned to perform a job under Article 20.01, he shall have the opportunity to call a member of the trades committee or a shop steward and file his complaint by completing a questionnaire provided. The employee assigned the work shall perform the job until the complaint has been resolved in accordance with the provisions of this Article.
- (b) A copy of the questionnaire shall be provided to the complainant, Union, and Trades Committee representative or Shop Steward.

20.05 If a complaint is filed, a sub-Committee will be convened as soon as possible but not later than five (5) working days to investigate it.

- (a) The sub-Committee shall consist of one (1) member from the Company and one (1) member from the Union.
- (b) The terms of reference of the sub-Committee shall be:

- i) What trade group(s) has performed the disputed work in the past at the operation defined in Article 20.01;
- ii) Where the Company admits having (or is found to have) breached this Article, it will pay to the Union damages to be calculated on the basis of one (1) hour's pay for each hour of breach to a maximum of twelve **(12)** hours with respect to each continuing breach.

20.06 Following investigation of the factors referred to in Article **20.05 (b)**, the sub-Committee will make non-binding recommendations to the Company and the Union regarding the complaint and render its recommendations (if any) in writing forthwith.

20.07 In the event that the sub-Committee cannot agree on the recommendations referred to in Article **20**, Sub-section **20.06** or in the event either party disagrees with the recommendations made, then:

- (a) The parties agree that the Manager, Human Resources and the President of U.S.W.A., Local **7619** will attempt to resolve the dispute
- (b) When the Manager, Human Resources and the President of U.S.W.A., Local **7619** can not resolve a dispute, then either party may,

within ten (10) days, refer the matter to binding mediation.

20.08

- (a) Vincent L. Ready shall investigate all matters referred to binding mediation and in the event that he is unable to resolve a dispute, he shall forthwith publish recommendations which shall be binding upon the parties.
- (b) All investigations and recommendations under Article 20.08 shall be made taking into consideration (among other things) the following:
 - i) The express desire of the parties to obtain the greatest efficiency of operations, and
 - ii) The need to define common tasks.

20.09 For the purposes of this Article, "days" shall not include Saturdays, Sundays and Statutory Holidays.

20.10

- (a) It shall also be the responsibility of the Joint Trades Committee to meet at the call of either the Company or the Union for the purpose of discussing Trades related problems including, but not limited to:

- i) Apprentice Training
 - ii) Apprentice Rotation
 - iii) Apprenticeship Opportunities
 - iv) Journeyman Training and Upgrading
- (b) The Co-chairmen of the Joint Trades Committee shall meet and prepare an agenda at least five (5) days prior to any scheduled meeting.
- (c) The Joint Trades Committee shall make recommendations to the Company concerning such matters.

ARTICLE 21 -TECHNOLOGICAL CHANGE

21.01 The Company and the Union agree that technological change is both necessary and desirable for the viability of the Company and the ongoing security of its employees.

In recognition of the foregoing, the Company undertakes to reduce the effects of technological change on the job security and earnings of employees who are laid off, or permanently demoted as a direct consequence of technological change. Any dispute regarding the implementation of technological change shall commence at step three of the grievance procedure.

21.02 For the purpose of this agreement, a technological change shall be defined as the automation of equipment, or the mechanization or automation of duties which adversely affects employees in the bargaining unit through lay *off* or demotion from their present job classification.

21.03 In order to lessen the effects on employees who are adversely affected as a result of technological change, it is agreed that:

- (a) The Company shall notify the Union in writing not less than six (6) months in advance of intent to institute technological change. The Company shall then meet with the Union to explain the technological change, setting forth the estimated number of employees affected, together with the nature and extent of the change anticipated.
- (b) The Company will cooperate with the Provincial or Federal Governments and participate in every way possible in training or retraining of employees affected by technological change. This shall include educational leaves of absence for retraining, if required.
- (c) An employee who is set back to a lower paid job as a result of technological change will receive the rate of his regular job at the time of the setback for a period of three (3) months. For a further period of three (3)

months, the employee will receive an adjusted rate which will be midway between the rate of his regular **job** at the time of the setback and the rate **of** his new job. At the end of this six (6) month period the rate of his new regular job shall apply.

- (d) New jobs created by technological change shall be evaluated in accordance with Article 15, Sub-section 15.03.
- (e) Employees who terminate, are laid off or displaced from their regular jobs because of technological change shall be entitled to one week of severance pay for each year of service with the Company. The amount calculated under such entitlement shall not exceed a maximum of twenty six **(26)** weeks **pay**.

21.04 During and for the term of this agreement, the Company and the Union will each appoint 3 members to a committee which shall meet at the call **of** either the Company or the Union for the purpose of making recommendations to the Company with respect to mitigating the impact of technological changes on the employees of the Company. The Company will give due consideration to such proposals.

ARTICLE 22 - TRAINING

GENERAL

22.01

- (a) The Company has the responsibility for the efficiency of the operation. In recognition, however, of the desirability of providing backup and versatility to ensure continuity of operations and to provide employees with an opportunity to qualify for higher paying jobs, the Company agrees, in cases referred to in Article 9.01, to provide training once it establishes that an employee possesses the minimum qualifications to perform the work.

- (b) Such training shall be provided in the following manner, subject to the requirements of efficient operations:
 - i) Except in the Heavy Equipment Operator lines of progression, every effort will be made by supervision to train each employee to perform the work of the next job in that employee's Line of Progression.

 - ii) In a case where an employee has been awarded a job pursuant to the provisions of Article 10 but has not completed the training for that job, the Company shall provide a reasonable opportunity to complete that training.

- iii) Should the trainee feel that some aspects of the training are not going well, he **is** encouraged to talk to **his** immediate Supervisor.

- iv) Should the Supervisor feel that the trainee is not responding to the training in total or in specific areas, he is encouraged to discuss the situation with the employee. If the employee feels the Supervisor's evaluation is unjust he is encouraged to discuss the situation with the Supervisor in the presence of his Shop Steward.

22.02 Determination of qualifications and provision for reasonable training opportunities shall be made by the Company in a just manner. Whether the Company made such determination in a just manner shall be subject to the Grievance Procedure.

22.03 Where formalized Training Programs exist or are proposed, copies of such Programs and manuals must be supplied to the Union.

22.04 On shifts where training is contemplated, the Company shall consider the seniority of employees who have expressed an interest in the training of employees.

22.05 Employees who have been specifically instructed to train other employees shall be paid

a premium of \$0.50 per hour for each hour in which they are engaged in such training.

22.06 The Company will select applicants for training in accordance with the provisions of Article 9.01. The Company may reject applicants who have poor work records.

22.07 Successful applicants for Training Programs shall be given a course outline, appropriate training manuals and a planned schedule of training. The employee's schedule and progress will be reviewed with him on a regular basis.

22.08 The Company may, from time to time during the term of this Collective Agreement, develop new or revise current Training Programs consistent with the needs of **its** operations.

22.09 Promotion through the various levels or wage grades in a Training Program while related to service as indicated in the various Programs, shall be dependent on the following factors before promotion to the next wage grade.

- (a) Successful completion of the test provided by the Company, where applicable, and
- (b) Supervisory assessment of practical performance as out in Article 22.02.

22.10 Employees who do not meet the requirements of Article 22.09 above with respect to promotion, and if further training is considered justifiable, then such employee shall be eligible for re-evaluation and testing at appropriate intervals determined by the Company.

22.11 Employees who do not meet the requirements of Article 22.09 above may be terminated from the Program at intervals or check points in accordance with the individual Training Programs and reassigned to his former classification if there is a vacancy. Where no vacancy exists he may exercise his company seniority on bid entry jobs.

22.12 The Training provisions set forth in Article 22.09 above shall apply:

- (a) For a period of time sufficient to learn to perform the specific job.
- (b) To provide replacement for vacancies or anticipated job vacancies.

22.13 Where training programs exist, in the Mine and Mill Departments, to train employees to operate several types of equipment or perform various duties within a classification, then in order to qualify for the rate an employee must be able to proficiently perform the work associated with that classification.

22.14 In order to complete training in an efficient and productive manner, employees will have normally averaged fifty (50%) percent of their regular scheduled hours in training during each phase of the Training Program. This schedule is subject to operational factors and individual abilities.

22.15 When an employee has completed training as contemplated in Article 22.01, he must perform the jobs for which he has been trained when assigned to do so by his supervisor. The Company encourages rotation within the respective Mill Operator classifications in the mill shift lines of progression. However, rotation is voluntary.

MILL

22.16 The Company shall have and maintain a Trained Operators List sufficient to meet the requirements of Mill Operations while employees are absent from the workplace.

22.17 An employee who completes a training program in Mill Operations shall have his name added to the Trained Operators List in order of his department seniority. If there are no vacancies in this classification he shall return to his former classification. The list will be updated and posted every three (3) months.

22.18

- (a) The Equipment Operator I and II positions are for training only
- (b) The training hours in the equipment operators line of progression are:
 - Equipment Operator I - 48 Hours
 - Equipment Operator II - 240 Hours
 - Equipment Operator III - 780 Hours
- (c) All interested MSU I operators will be given the opportunity, in accordance with 22.01, to be trained to the MSU II level.
- (d) All interested Utilitymen will be given the opportunity, in accordance with 22.01, to be trained in the Mill Operator I and II competency areas.

All interested Mill Operator I's will be given the opportunity, in accordance with 22.01, to be trained in the Mill Operator II and Mill Operator III competency areas.

All interested Mill Operator II's will be given the opportunity, in accordance with 22.01, to be trained in the Mill Operator III competency areas.

- (e) Employees, who have completed the requirements for the Mill Operator I level, will be eligible to apply to be trained as a Leach Plant Operator or Cyclone Operator II.

Leach Plant Operators or Cyclone Operator II's will return to the Mill Operations Line of Progression at the Mill Operator I or II level depending upon their qualification and upon the level of the vacancy.

- (f) When MSU II's are relieving Equipment Operators who are on vacation, they will only operate equipment listed for Equipment Operator I and II.

22.19 The Company may apply a training rate to a trainee on any job only during the time when another employee, other than the trainee, is on the job, provided the training rate applied is the higher of:

- i) The hourly rate of the job which he currently holds on a full time basis, or
- ii) The hourly rate of the job he would have been performing that shift had he not been assigned to training.

MINE DEPARTMENT

22.20 Where vacancies exist in a Heavy Equipment Training Program in the Mine Department, the Company will post such vacancies in accordance with the provisions of Article 10.

22.21 An employee who completes a training program in Mine Operations shall have his

name added to the Backup Operators List in order of his department seniority. If there are no vacancies in this classification he shall return to **his** former classification.

22.22 Shovel Operator I & II, D.L.G. Operator I & II, Drill Operator I & II, Blaster Operator I & II and Cableman I referred to in article 22.28 and in the lines of progression for Mine Operations are for training purposes only and are not permanent job classifications.

22.23 The training rate applied to a trainee in the Mine Operations Department will be consistent with the training rates set *out* in the wage schedules for periods of time set forth in Article 22.28.

22.24 The Company shall have and maintain a list of trained backup operators sufficient to meet the requirements of Mine Operations while employees are absent from the work place. The backup operator requirements will be adjusted upwards if more equipment is utilized or downward if less equipment is utilized.

Based upon the current equipment utilization this results in a minimum of:

- (a) Two (2) Backup Shovel Operators available on each shift.

- (b) Four **(4)** Backup Dozer, Loader, Grader Operators available on each shift.
- (c) One **(1)** Backup Drill Operator available on each shift.
- (d) One **(1)** Backup Cableman available on each shift.
- (e) One **(1)** Backup Blaster Operator available on each shift.

22.25 In order to maintain a high level of skill among the backup operators in mine operations listed in article 22.24 above, there will be daily rotation among the backup operators on the shift. The company will balance the operating time every 2 months.

22.26 The employee will remain on the backup operators list for a period of two (2) years before he may request to be taken off the backup operators list. (Such request must be in writing to his supervisor and **will** not be considered until a replacement has been trained) Employees will be allowed to post on apprenticeships and jobs outside of the department.

22.27 An employee may only be on one (1) Backup Operators list at any given time.

22.28

- (a) The required training hours for advancement through trainee positions shall normally be:

1) Shovel Operator	I to II	240 hours
	II to III	456 hours
2) Dozer, Loader	I to II	240 hours
Grader Operators	II to III	456 hours
3) Drill Operator	I to II	240 Hours
	II to III	336 hours
4) Cableman	I to II	192 hours
5) Blaster Operator	I to II	300 hours
	II to III	300 hours

22.28

- (b) Exceptions to the normal accumulation of training hours may be made in recognition of an employee's previous operating experience.
- (c) The above training hours reflect the normal training period based upon equipment presently in operation at Highland Valley Copper. These hours may be varied as equipment is added to or deleted from the operation.

22.29 In the case of the Mine Department, in order to qualify as a Dozer Grader F.E.L. Operator III (Wage Grade 8), the operator must be able to proficiently operate the four (4) major pieces of equipment used by the Mine Department. These are large front-end loaders,

road graders, rubber-tired dozers and track dozers.

22.30 The proficiency will be determined by testing the operator's skill in performing all of the work required in the department. Upon attaining the rate, the operator will be expected to do all of the jobs assigned to him for which he is not limited to assignment on the above mentioned equipment, but may be assigned other work in accordance with the terms of the Collective Agreement, and from time to time, in order to allow training opportunities for trainees.

22.31 When assignments are made to specific types of equipment (e.g. dozers, graders, front-end loaders), the senior employee shall normally be entitled to preference. It is agreed by the Company and the Union that when operational requirements dictate assignments contrary to seniority, it shall be allowable for a reasonable period of time (e.g. if a junior employee is being trained for a more senior employee's piece of equipment, the assignment would be only for that period of time to allow the junior employee to become proficient on the equipment).

22.32 Every six (6) months Mine Operations operators shall indicate their preference as to the type of equipment (either track dozer, grader, front-end loader, rubber-tired dozer) they wish to operate, but may only change equipment in the event of a vacancy.

22.33 In the event of a vacancy on a piece of equipment due to termination or some other cause, the senior employee making application **for that piece of equipment shall normally be** allowed to operate the equipment at the time the vacancy is created. It is agreed that no operator may claim one (1) particular machine for operating preference.

22.34 Employees in Mine Operations, who are awarded a training posting, may withdraw from the posting if their training has not started within six (6) months of being awarded the posting. Such withdrawals must be done in writing to their supervisor, at which time they will be eligible to post for jobs posted under the terms of Article 10 of the collective bargaining agreement.

22.35 Employees will carry their back up jobs when transferred between crews.

ARTICLE 23 - APPRENTICESHIP PROGRAM AND TRADES TRAINING

23.01 The purpose of this Article is to provide unskilled employees with the opportunity to receive occupational and vocational training through an apprenticeship. The use of equitable apprenticeship selection criteria will give the Company reasonable assurances that the apprentice, upon completion of his

indentureship will become a proficient tradesman.

23.02 The educational requirements established by the Provincial Government body administering apprenticeships will be the minimum educational standards for candidacy as an apprentice.

23.03

- (a) In selecting applicants for Apprenticeship Training, the Company shall post its requirements as set out in Article 10.02, and the selection shall be based upon the seniority of applicants who are qualified as established in Article 23.02 and who successfully complete the pre-apprenticeship examination set out in Article 23.04(c).

- (b) Certified Journeymen who have been displaced from their trade classification will be accepted as candidates for apprenticeships. Where a displaced tradesman bids and is the successful applicant for an apprenticeship, more senior employees in the same trade from where he was displaced will be given the opportunity to take the apprenticeship opening on the basis of their company seniority. If a more senior tradesman exercises his seniority to claim the apprenticeship opening and if the company decides it needs to replace him in

his former classification then the senior displaced tradesman with recall rights will be recalled.

23.04 The pre-apprenticeship testing procedure will be as follows:

- (a) Tests recommended for self-evaluation will be made available to employees on request. Failure to take such tests shall not jeopardize an employee's application for apprenticeship.
- (b) Formal apprenticeship selection testing will be done on Company property on Company time within fourteen (14) days of the expiry of the relevant job posting. A Union representative will be present when the tests are given and marked.
- (c) Passing grades for the apprenticeship selection tests have been established as being a requirement of seventy-five percent (75%) in each of the mechanical aptitude, space relations and shop math.
- (d) All scoring computations of percentages in each section will be rounded off to the next highest percentage point where any fraction of a percentage point exists.
- (e) Where an applicant has failed to pass one or more sections, the employee will be

allowed to bid and be retested one (1) additional time. Further retesting will only be allowed where the employee can demonstrate to the Company that some relevant upgrading has taken place since the last failure.

- (f) The signing of Apprenticeships will be dated on successful completion of the pre-apprenticeship testing procedure and selection pursuant to Article 23.03.

23.05 The course content of Training Programs, evaluation of Apprentice performances and matters related thereto or regulated by statute or government regulations shall not be subject to the Grievance Procedure.

23.06

- (a) In the event of a reduction of forces, Apprentices shall be laid off in accordance with their Apprentice seniority within the group of Apprentices within their trade.
- (b) An Apprentice, who has been laid off pursuant to paragraph (a) above, shall be entitled to all rights of any employee under this Agreement, including those set forth under Article 9 - Seniority.

23.07

- (a) For an Apprentice absent from the job due to attendance at the Government Apprentice School, the Company shall pay

the Apprentice his regular pay. Should an Apprentice fail to pass the school term examinations and is permitted to repeat the same, the Company shall pay the Apprentice as provided herein upon successful completion of school term examinations. The Company's obligation is limited to one repeat during the term of the apprenticeship.

- (b) An apprentice who fails to complete his apprenticeship shall be reassigned to the classification he held prior to entering the apprenticeship program if there is a vacancy. Where no vacancy exists he may exercise his company seniority on bid entry jobs.

23.08 The basic hourly rates for Apprentices shall be in accordance with the Appendix 'A' wage schedule.

23.09

- (a) The Company shall provide payment of \$4.00 for each day of attendance at Government provided apprenticeship training. Such payment will be made following the training and upon receipt of the Apprentice's Grades.
- (b) The Company shall reimburse an employee who submits receipts, up to two hundred fifty dollars (\$250.00) during the period of

his indentureship for the purchase of required textbooks.

- (c) The Company shall reimburse an employee who submits receipts, up to seven hundred fifty dollars (\$750.00) each year of successful completion of his technical training during his indentureship.

23.10 The Company and the Union agree to implement the concept of Apprentice Rotation through departments in order to provide broad exposure in the trade concerned.

23.11

- (a) Warehouse Apprenticeships

The selection of candidates for warehouse apprenticeships will be in accordance with Article 23.03.

- (b) Certified Warehouseperson I

Completion of Apprenticeship in Industrial Warehousing and in house training programs as required, with emphasis given to JDE training.

Certified Warehouseperson II

To progress to Warehouseperson II, Wage Grade Eight (8), the employee will complete eighteen hundred (1800) hours as a Certified Warehouseperson I and acquire the following educational requirements:

C.I.T.T. - Distribution I

or

P.M.A.C. - Principles of Buying

or

I.M.M.S. - M.M. 1 and M.M. 2

and complete eight (8) hours of training in either:

Materials Analyst Expediting functions

or

Materials Analyst Inventory Control functions

or

Purchasing functions

Access to this job training will be at the Supervisor's discretion, and he may elect to start the job training prior to completion of the above courses, but the job training will be scheduled and completed within two (2) months of the certificate of completion being presented to the Company.

Certified Warehouseperson III

To progress to Warehouseperson III, Wage Grade Nine (9), the employee will complete eighteen hundred (1800) hours as a Certified Warehouseperson II.

and complete sixteen (16) hours of training in two of the remaining functions of either Materials Analyst Expediting, Materials Analyst Inventory Control or Purchasing.

- (c) Current incumbents in the warehouse who have obtained their trades qualifications as warehouseperson will be paid wage grade seven (7). Those individuals who do not have qualifications as a certified warehouseperson and who choose not to join the Apprenticeship program will be grandfathered according to their qualifications, that is Warehouseperson I, II, or III.
- (d) Upon successful completion and pursuant to the provisions of Article 17.05 the Company will pay the cost of courses for those individuals in the warehouse who wish to continue their education in either C.I.T.T., P.M.A.C. or I.M.M.S.

23.12

- (a) Welding Apprenticeships

The selection of candidates for this position will be in accordance with Article 23.03.

Apprentices will be required to successfully complete training as described in this Article, pass an Interprovincial Trades Qualification examination for welders, and complete eight thousand (8,000) hours of

experience in the trade to achieve the designation of journeyman welder.

- (b) The hours required for each year of apprenticeship are:

First Year Apprentice

Hours as assigned.

Second Year Apprentice

Complete two thousand (2,000) hours of experience.

Third Year Apprentice

Complete four thousand (4,000) hours of experience.

Fourth Year Apprentice

Complete six thousand (6,000) hours of experience.

Journeyman Welder

Pass Interprovincial Trades Qualifications examination and complete eight thousand (8,000) hours of experience.

23.13 For the term of this Collective Agreement, the Company agrees that all trades training opportunities will be posted and filled by apprentices. Pursuant to Article 23.05, uncertified tradesmen who have the minimum requirements set out by the Provincial Government body that administers Apprenticeships may be eligible to apply to write an examination

for a British Columbia Certificate of Qualification in their trade. Upon successful completion the employee would be assigned to Journeyman status, Wage Grade Nine (9).

ARTICLE 24 -TERM OF **AGREEMENT**

24.01 This Agreement shall become effective on October 1, 2003 and shall remain in full force and effect until and including the 30th day of September 2006.

Either party may request the negotiation of a new Agreement by giving written notice to the other party during the four (4) months preceding its termination. The provisions of this agreement shall remain in effect during such negotiations. Dated **at** Kamloops B.C. this 20th day of January, 2004.

For Highland
Valley Copper

For the United
Steelworkers of America

R.J. Killough

R. Boyce

R.M. Chenier

S. Hunt

F.B. Amon

C. Landry

J.D. Clark

J. McCarthy

C.R. Rondestvedt

A. Lukinchuk

L.S. Streit

L. Henrikson

J.D. Price

B. Karsten

P.J. Rouleau

P. Martel

D.R. Assmus

R. Landsburg

R.S. Dhaliwal

B. Froment

S. Steadman

E.J. Anderson

J.M. Piwek

APPENDIX A
Wages
AND
APPENDIX B
Wage Grade Schedule

146

APPENDIX A

EFFECTIVE DATES

RATES FOR CLASSIFICATION IN
APPENDIX B

TERM OF AGREEMENT
OCTOBER 1, 2003 TO
SEPTEMBER 30, 2006

W A G E S

Wage Grade	Oct. 1, 2003 5.0%	Oct. 1, 2004 3.0%	Oct. 1, 2005 3.0%
1	\$ 20.57	\$ 21.19	\$ 21.82
2	\$ 21.17	\$ 21.81	\$ 22.46
3	\$ 21.76	\$ 22.41	\$ 23.08
4	\$ 22.48	\$ 23.15	\$ 23.85
5	\$ 23.29	\$ 23.99	\$ 24.71
6	\$ 24.15	\$ 24.87	\$ 25.62
7	\$ 24.95	\$ 25.70	\$ 26.47
8	\$ 25.73	\$ 26.50	\$ 27.29
9	\$ 28.26	\$ 29.11	\$ 29.98

WAGES

(A) Copper Bonus

For the purpose of this agreement, the copper bonus payable during the calendar quarter (the payment quarter) shall be determined by the average price of copper in Canadian dollars in the preceding calendar quarter (the measurement quarter).

The average price of copper in a measurement quarter shall be determined by averaging the average monthly copper price for each month in the measurement quarter as determined using the London Metal Exchange settlement quotation for copper as published in Platt's Metals Week under the heading "L.M.E. Settlement," converted to Canadian dollars using the average monthly U.S. dollar to Canadian dollar exchange rate. The conversion to Canadian dollars will be made using the monthly average of the Bank of Canada's daily Canadian dollar to U.S. dollar closing rate. The average price of copper in Canadian dollars shall be rounded up or down to the nearest whole cent.

Based upon the average price of copper in Canadian dollars in the measurement quarter, bonus payments, as a percentage increase to the base rate shall be payable for the payment quarter to the following schedule.

Average Copper Price:	Bonus Payment:
\$1.27 Cdn. or greater	+6%
\$1.26	+5%
\$1.25	+4%
\$1.24	+3%
\$1.23	+2%
\$1.22	+1%

The above bonus payment calculation shall be applied to all wage dependent earnings of all

bargaining unit employees during the measurement quarter. Any funds payable under this plan will be allocated to the purchase of improved pension benefits under the Highland Valley Copper Pension Plan for Hourly-Paid Employees. (the "Plan").

Specifically, when the total cumulative copper bonus is at least equal to \$2,300,000 the normal form of pension in the Plan will change from joint and survivor pension with a survivor benefit of 50% to joint and survivor pension with a survivor benefit of 60%. The Plan will be amended to adopt this improvement. After such amendment, the cumulative copper bonus shall be reduced by \$2,300,000. This benefit improvement will be effective as of the start date of the payment quarter in which the cumulative copper bonus from the measurement quarter reaches \$2,300,000. Any employees who retire during the payment quarter shall be eligible to receive a joint and survivor pension at 60 per cent.

Thereafter, each \$2,400,000 increase in the total cumulative copper bonus shall increase the monthly rate of lifetime pension, for past and future service by \$1. The Plan shall be amended to increase the life time benefit for past and future service. The monthly rate of lifetime pension shall be increased by the greatest multiple of \$1 allowable such that the value of the increase does not exceed the cumulative copper bonus. After such amendment, the

cumulative copper bonus shall be reduced by \$2,400,000. These benefit improvements will be effective as of the start date of the payment quarter in which the cumulative copper bonus from the measurement quarter reaches \$2,400,000. Any employees who retire during the payment quarter shall receive the amended pension amount.

Such amendments shall occur no more frequently than quarterly.

At September 30, 2006, any then remaining cumulative copper bonus shall be used to increase the amount of lifetime pension. For each \$2,400,000 in the cumulative copper bonus, the lifetime pension will increase by \$1 for past and future service. The amount of increase shall be such that the value of the increase equals the remaining cumulative copper bonus, even if such calculation results in an increase that is not in a whole dollar increment. The plan will be amended to incorporate this increase in the benefit level.

A quarterly statement will be provided to the union on the status of the copper bonus account and this will also be subject to an annual review by the Partnerships external auditors.

APPENDIX B

WAGE GRADE SCHEDULE

Wage Grade

- 9 Shovel Operator III
 - Journeyman (certified) (Welder A Ticket)
 - Certified Warehouseperson III
 - Process System Technician III
 - Metallurgical Technician III
 - Mine Technician III
 - Chemist
 - Intermediate Accountant
 - Materials Analyst III
 - Blaster Operator III
 - Chemical Technician III
 - Systems Analyst
 - Network Analyst
 - Mill Operator III
 - System Support Technician

- 8 Rotary Drill Operator III
 - Mobile Crane Operator III
 - Industrial Instrumentation Mechanic II
 - Boilermaker-Welder III
 - (Welder B Ticket tested by Company)
 - Leach Plant Operator
 - Uncertified Trades
 - Equipment Operator III (tested by Company)
 - Dozer-Grader F.E.L. Operator III
 - (tested by Company)
 - Cableman II
 - Certified Warehouseperson II

- Chemical Technician II
- Process System Technician II
- Metallurgical Technician II
- Materials Analyst II
- Mine Technician II
- Tireman III
- Accounting Analyst II
- Senior Plant Analyst

- 7 Mobile Crane Operator II
- Dozer-Grader F.E.L. Operator II
- Cyclone Operator II
- Haulage Truck Operator
- Tire Repairman II
- Rotary Drill Operator II
- Boilermaker-Welder Improver
(Welder C Ticket)
- Shovel Operator II
- Certified Warehouseperson I
- Materials Analyst I
- Accounting Analyst I
- Plant Analyst
- Blaster Operator II
- Mill Operator II
- Equipment Operator II
- Water Sewer Treatment Operator

- 6 Industrial Instrumentation Mechanic I
- Tire Repairman I
- Rotary Drill Operator I
- Dozer-Grader F.E.L. Operator I
- Shovel Operator I
- Cableman I

Chemical Technician I
Metallurgical Technician I
Mine Technician I
Process system Technician I
Blaster Operator I
Mill Operator I
Equipment Operator I

- 5 Uncertified Warehouseperson
 Mobile Crane Operator I
 Junior Analyst II
 Mill Services Utilityman II D/S

- 4 Wash Bay Attendant
 Utilityman
 Mill Services Utilityman I D/S
 Janitor III

- 3 Tool Crib Attendant
 Junior Analyst 1
 Janitor II

- 2 Janitor I

- 1 Student

*Certified means a certificate of apprenticeship or certificate of proficiency issued or recognized pursuant to the Apprenticeship and Tradesmen's Qualification Act and Regulations of B.C. made thereunder for electricians, machinists, heavy duty mechanics, pipefitters, gas mechanics, gas fitters, welders, instrument technicians,

millwrights, carpenters, heat vent & refrigeration mechanics, industrial warehouseperson and steel fabricators.

Note: It is understood that steel fabricators will continue to perform all trades work (including welding) which they have traditionally performed for the company.

RATES OF PAY FOR
INDENTURED APPRENTICES

<u>Apprentice</u>	<u>Wage Grade</u>
First Year	2
Second Year	3
Third Year	5
Fourth Year	7
Fifth Year	8

WAGE GRADE QUALIFICATIONS

155

WAGE GRADE QUALIFICATIONS

Qualifications Lines of Progression Administration Accounting and M.I.S.

Accounting	<u>Wage Grade</u>
Intermediate Accountant Grade 12 Word Processing 40 WPM Completion of 3 year level recognized accounting course. 1 year as Accounting Analyst 2 MS Word and MS Excel	9
Accounting Analyst - II Grade 12 Word Processing 40 WPM Completion of 2nd year level recognized accounting course. 1 year as Accounting Analyst 1 MS Word and MS Excel	8
Accounting Analyst - I Grade 12 Word Processing 40 WPM Completion of 1st year level recognized accounting course.	7

Management Information System

Operators

Wage Grade

Systems Support Technician 9

Co-operative Education Diploma in a computer systems operations management program with relevant work term experience.

OR

Computer Systems Diploma or Degree with one year of industry experience in computer end-user support or helpdesk.

OR

Grade 12 with three years of industry experience in computer helpdesk or end-user support.

PLUS

Completed courses and experience with the current versions of Microsoft Office.

PLUS

Knowledge and demonstrated experience in network/PC administration and problem solving.

PLUS

Knowledge and experience in Microsoft's current network operating systems including:

Successful completion of the exams required for the Microsoft Certified Desktop *Support Technician* program

OR

Successful completion of one Client Operating System exam and one Networking System exam in the Microsoft Certified Systems Engineer program or the *Microsoft Certified Systems Administrator* program.

Wage Grade

Systems Analyst 9

- Minimum 2 year computer programming and systems analysis diploma.
- Minimum 3 years of industry experience in computer programming and systems analysis. Knowledge and experience working in/with a business area.
- JDE - AS/400 knowledge and experience.
- MS Access or SQL database knowledge and experience

Network Analyst 9

- Minimum 2 year computer programming and systems analysis diploma.
- Minimum 3 years of industry experience in computer programming, systems analysis or network systems support.
- Knowledge and experience in Novell's Netware (Novell's CNE/CNA training curriculum) and or Microsoft's NT (Microsoft's MCSE training curriculum) network operating systems.
- MS Access or SQL database knowledge and experience.

Mine Technician - II	a
<ul style="list-style-type: none"> - Completed course equivalent to B.C.I.T. Mining Technician - One (1) year's related work experience 	
Mine Technician - III	9
<ul style="list-style-type: none"> - Educational requirements of Mine Technician I - Word Processing 20 w.p.m. - MS Word, MS Excel and Database - Basic Autocad (Cariboo College YVOC393 or equivalent) - Three (3) years' related work experience - Microsoft Windows - GEMCOM - Global Positioning System (GPS) - Geographical Information System (GIS) 	

Milling

Wage Grade

Chemical Technician - I	6
<ul style="list-style-type: none"> - Completed course equivalent to B.C.I.T. Chemical Sciences Technology Diploma 	
Chemical Technician - II	8
<ul style="list-style-type: none"> - Completed course equivalent to B.C.I.T. Chemical Sciences Technology Diploma - One (1) year related work experience 	

Chemical Technician - III	9
<ul style="list-style-type: none"> - Completed course equivalent to B.C.I.T. Chemical Sciences Technology Diploma or BC Assayers Certificate or equivalent. - MS Excel and Database - Three (3) years related work experience 	
Metallurgical Technician - I	6
<ul style="list-style-type: none"> - Completed course equivalent to B.C.I.T. Metallurgical Technician 	
Metallurgical Technician - II	a
<ul style="list-style-type: none"> - Completed course equivalent to B.C.I.T. Metallurgical Technician - One (1) year's related work experience 	
Metallurgical Technician - III	9
<ul style="list-style-type: none"> - Educational requirements of Metallurgical Technician I - Word Processing 20 w.p.m. - MS Word, MS Excel, Database - Basic Autocad Course (Cariboo College #YVOC393 or equivalent) - Three (3) years' related work experience 	
Process Systems Technician - I	6
<ul style="list-style-type: none"> - Completed Course equivalent to B.C.I.T. Computer - Programming Diploma (Two Years) 	

- Process Systems Technician - II 8
- Education requirements of Process Systems Technician I
 - word processing 20 w.p.m.
 - One (1) year related work experience in digital communications

- Process Systems Technician - III 9
- Educational requirements of Process Systems Technician II
 - Basic Autocad Course (Cariboo College #YVOC393 or equivalent)
 - Three (3) years' related work experience

Qualifications Lines of Progression Mine and Mill Departments

- Wage Grade
- Senior Plant Analyst 8
- 1 year as a Plant Analyst and completion of one of the following
- i) 2nd year level recognized accounting course, or
 - ii) level 2 PMAC or equivalent CITT
- Plant Analyst 7
- Grade 12
- Typing 40 WPM
- 3 years as Junior Analyst I and II or equivalent

MS Word and MS Excel
and
completion of one of the following:
1st year level recognized accounting course
or
level 1 PMAC or equivalent CITT

Junior Analyst - II 5
Grade 12
Word Processing 40 WPM
MS Word and MS Excel
1 year at Junior Analyst I.

Junior Analyst - I 3
Grade 12
Word Processing 40 WPM
MS Word and MS Excel

The above represent minimum qualifications. The formal education qualifications may be met and replaced by appropriate practical experience to perform the job. Vacancies shall be filled by the senior applicant who meets the minimum qualifications or who can demonstrate the present ability to perform the duties of the job at the equivalent technical level.

Employees planning to enroll in a course, to meet wage grade qualifications, must consult with their supervisor to ensure that the course is recognized and or meets the equivalency requirements prior to enrolling.

**Industrial Instrumentation
Mechanic**

Wage Grade

Industrial Instrumentation Mechanic - I 6
Must have an Instrumentation Technologist diploma / certification from a recognized post secondary education institution

Industrial Instrumentation Mechanic - II a
Must have an Instrumentation Technologist diploma / certification from a recognized post secondary education institution and one completed year of working in the trade.

Journeyman 9
Must have an Instrumentation Technologist diploma / certification from a recognized post secondary education institution.

Have successfully challenged the Inter Provincial Exam, at any time following the date of hire.

Janitor

Wage Grade

Janitor - III 4
All requirements of Janitor II and Completion of Building Service Worker Course from U.C.C. or equivalent
1 year at Janitor II

Janitor - II	<u>Wage Grade</u> 3
Successful completion of the Betco Janitor Training Modules and exams	
Janitor - I	2
Entry Level	

Wage Grade Qualifications

In the Mill Operations Department, in order to qualify for the following, an operator must be able to perform the work functions related to the following areas:

	<u>Wage Grade</u>
a) Utilityman	4
<ul style="list-style-type: none"> - Shift Labourer - Leach Plant Helper - Reagent Mixing/Lime Slaking - Operate all Bob Cats - Sampling, Conveying Systems, Cyclone I. 	
Mill Operator I	6
<ul style="list-style-type: none"> - Sampler - Conveying Systems - Cyclone I And functions performed by the Utilityman	
Mill Operator II	7
<ul style="list-style-type: none"> - Filter/Drying - Crushing 	

- Grinding
- Dredge Operator

And functions performed by the Mill Operator I

Mill Operator III 9

- Moly Flotation
- Bulk Flotation
- Control Room

And functions performed by the Mill Operator II

Wage Grade

b) Mill Services Utilityman I 4

- Labourer
- Moly Packing
- Personnel Driver
- Hyab
- Garbage Truck
- Bob Cats

Mill Services Utilityman II 5

- Bob Cats
- Pebble Crusher
- Cat Loader
- Ball Truck
- High Vac Truck
- Gardener
- 15 ton Crane
- PressureWasher Operator

And functions performed by MSU I

	<u>Wage Grade</u>
c) Equipment Operator I	6
- Dump Truck	
- Gravel Truck	
- Sand Truck	
- Water Truck	
 Equipment Operator II	 7
- Front End Loader	
- Rubber Tire Backhoe	
- Cranes up to 22 ton	
And functions performed at the Equipment Operator I level	
 Equipment Operator III	 8
- Grader	
- Dozer	
- Track Hoe	
- Cranes up to 65 ton	
- Low Bed	
And functions performed at the Equipment Operator II level	

LINES OF PROGRESSION

168

Mine Operations Lines of Progression

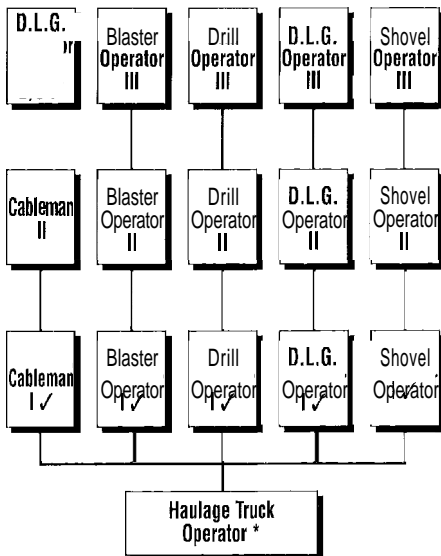

(✓) In awarding a training position, the job will be awarded to the senior applicant in the Mine Department Operations line of progression

Mine Maintenance Lines of Progression

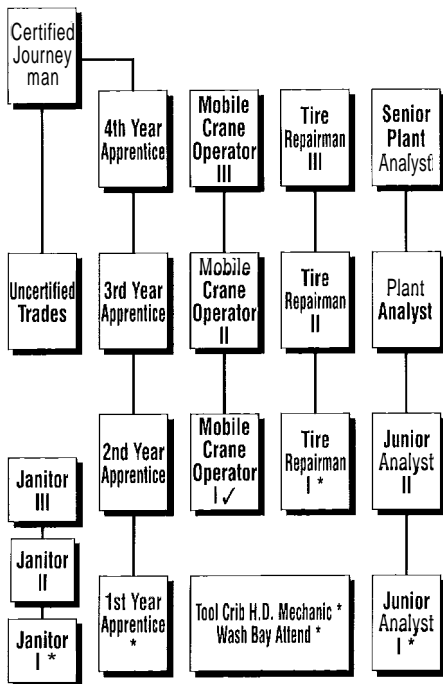

Mine Engineering

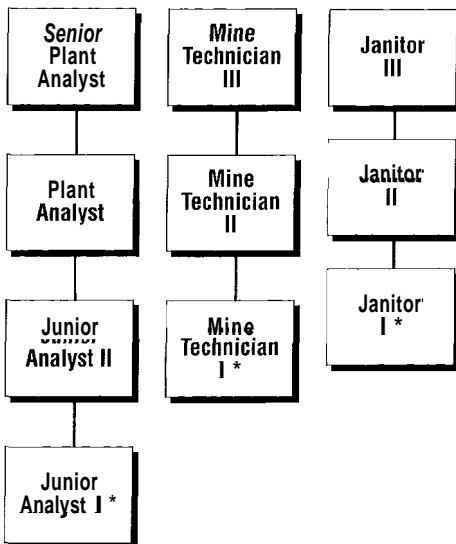

Mill Department Maintenance Lines of Progression

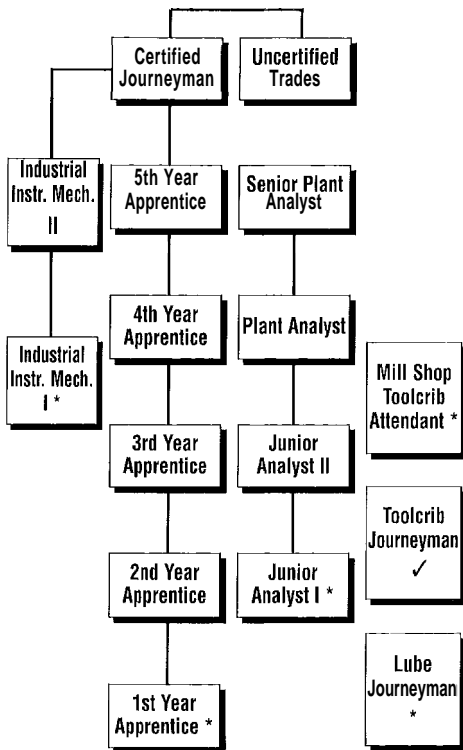

Mill Technical Lines of Progression

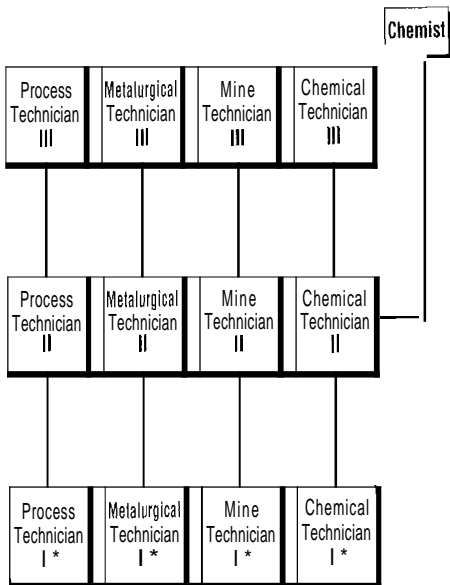

Administration Department
Lines of Progression
Materials Management (O&T) (P&M)

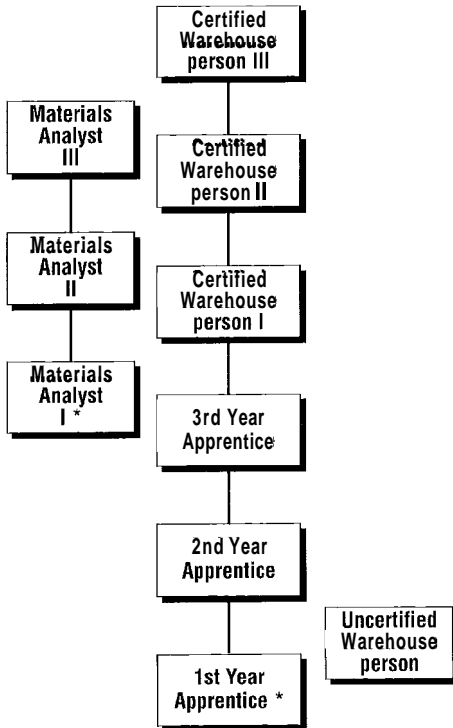

Administration Department

Accounting and Management Information Systems

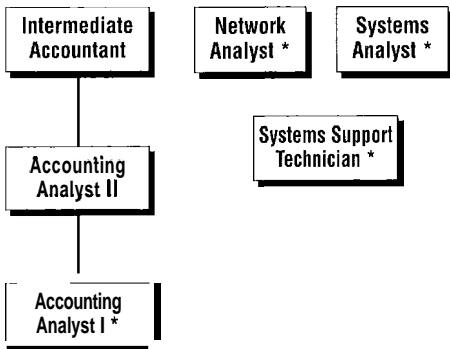

LETTERS INDEX
ADDENDUM "A"
HUMAN RIGHTS POLICY
AND
LETTERS OF
UNDERSTANDING

177

LETTERS INDEX

PROPERTY WIDE LETTERS	page
ADDENDUM "A" - HUMAN RIGHTS POLICY	172
HUMAN RIGHTS POLICY	173
ASSIGNMENT & REASSIGNMENT	182
RECALL OF LAID OFF EMPLOYEES TO DO CONTRACT WORK	183
HISTORICAL LIST ARTICLE 3.07(d) SUBSECTION (i)	186
CONTRACTING OUT PROCEDURE	188
LETTER OF ASSURANCE - NOTICE OF CONTRACTING OUT DATA BASE	192
VALLEY PIT STABILIZATION PROJECT	193
PENSION PLAN	195
SEVERANCE PROVISION	197
WORKFORCE REDUCTION 2004	199
MINE CLOSURE	203
MODIFIED WORK PROGRAM	206
CREATION OF JOBS FOR PEOPLE IN THE MODIFIED WORK PROGRAM	208
EXISTING LONG TERM DISABILITY RECIPIENTS ..	211
EMPLOYEE AND FAMILY ASSISTANCE PROGRAM ..	212
INSULATED COVERALLS	214
PAYMENT FOR LOSS TIME TO ATTEND COURSES ..	216
OFFICE AND TECHNICAL CLASSIFICATION	218
OFFICE AND TECHNICAL COMMITTEE	219
MAIL DELIVERY	221
DIVISION OF WORK: CONSTRUCTION OF TAILINGS DAMS	223
PRIME TIME VACATION	227
LETTER OF ASSURANCE	229
MILL DEPARTMENT LETTERS	
ASSAY LABORATORY LINE OF PROGRESSION	230

ON CALL DUTY AUTOMATION SYSTEMS - MILL TECHNICAL GROUP PROCESS SYSTEM TECHNICIANS	223
CYCLONE OPERATORS	236
SHIFT CHANGE PREMIUM FOR CRUSHER OPERATORS	237
1- UTILITYMAN, MILL OPERATIONS	238
UTILITYMAN/ MSU'S WORKING WITH MILL MAINTENANCE CREWS	240
BUMPING INTO THE UTILITYMAN'S POSITION MILL OPERATIONS AND FILLING A PERMANENT VACANCY IN THE UTILITYMAN'S CLASSIFICATION	242
FILLING A PERMANENT VACANCY AND LATERAL MOVES IN THE JOB CLASSIFICATIONS LISTED IN THE MILL OPERATOR I, II AND III LINE OF PROGRESSION	244
"LATERAL CREW TRANSFER REQUEST" - MILL OPERATOR I, II AND III CLASSIFICATIONS	246
BUMPING INTO THE MILL OPERATOR I, II & III	251
CREATION OF THE WATER SEWER TREATMENT OPERATOR MILL OPERATIONS	253
BACKUP OPERATORS LISTS FOR THE MILL PRESSURE WASHER	256
PAINTING IN MILL DEPARTMENT	259
TIMBERMAN / PAINTER	262
EQUIPMENT OPERATOR IV & 250 TON CRANE OPERATOR	264
START/STOP TIME - CONTINUOUS SHIFT MILL MAINTENANCE	266
START/STOP TIME - CONTINUOUS SHIFT MILL MAINTENANCE ELECTRICIANS & INSTRUMENT MECHANICS	268
VIBRATION READINGS MILL MAINTENANCE	270

MINE DEPARTMENT LETTERS	
SUPPORT EQUIPMENT AIR CONDITIONERS	272
BACKUP LISTS - MINE OPERATIONS	274
EQUITABLE DISTRIBUTION OF OVERTIME	
MINE OPERATIONS	277
ADMINISTRATION DEPARTMENT LETTERS	
M.I.S. LINES OF PROGRESSION CHANGES	280
CO-OP STUDENT PROGRAM - MANAGEMENT	
INFORMATION SYSTEMS. (M.I.S.)	282
MOVEMENT BETWEEN ACCOUNTING ANALYST I,	
MATERIALS ANALYST I, AND PLANT ANALYST	
LINES OF PROGRESSION	284
CREATION OF THE RELIEF PLANT ANALYST &	
REMOVAL OF THE PLANT ANALYST	
HUMAN RESOURCES	286

ADDENDUM "A"

HUMAN RIGHTS POLICY

The company and the union agree that this Human Rights Policy deals with and applies only to allegations that an employee has been subject to discrimination (which includes personal and sexual harassment) because of a protected category(s) of the Human Rights Code. The parties undertake to educate their principals as to the correct interpretation and application of this policy.

J.M. Piwek

A. Lukinchuk

S. Steadman

J. McCarthy

E.J. Anderson

HUMAN RIGHTS POLICY

PREAMBLE:

The objective of the Human Rights Policy is to ensure that all employees of Highland Valley Copper are assured of a work environment that is free of all forms of discrimination, including personal and sexual harassment. By introduction of this policy, it is the intention of Highland Valley Copper to ensure proper work place behavior and that the treatment of individuals is fair and equitable and in full compliance with all applicable Human Rights Legislation as well as Section 14 of the Mines Act and Article 1.01(c) of the Collective Agreement.

The Human Rights Code of the Province of British Columbia protects individuals from acts of discrimination with respect to employment, or any term or condition of employment because of a person's race, colour, ancestry, place of origin, political belief, religion, marital status, family status, physical or mental disability, sex, sexual orientation, or age of that person or because that person has been convicted of a criminal or summary conviction offense that is unrelated to the employment or the intended employment of that person.

DEFINITIONS:

Discrimination:

Discrimination is to treat a person differently because of that person's race, colour, ancestry, place of origin, political belief, religion, marital status, family status, physical or mental disability, sex, sexual orientation, or age, or because of a criminal or summary conviction that is unrelated to the employment or intended employment.

Harassment:

Harassment is a form of discrimination and therefore a violation of the Human Rights Code. Harassment may be direct or indirect. When Harassment is indirect, it results in a work environment that is considered to be "Poisoned". The work environment may be poisoned by crude language, sexist or racist remarks, unwelcome jokes and cartoons, nude or semi-nude pictures, displaying of racist or bigoted pictures or materials or other unwelcome conduct that creates an uncomfortable or hostile work environment for one or more employees.

Personal Harassment:

Personal Harassment, means any conduct that is unwelcome or that ought reasonably to be known to be unwelcome and includes, but is not limited to, vexatious comments or conduct, jokes, insults, threats, cartoons,

innuendo, or refusal to talk or work with a person for reason(s) that relate to any protected category of the Human Rights Code.

Sexual Harassment:

Sexual Harassment has been defined by the Supreme Court of Canada as any conduct of a sexual nature that is known or ought to be known to be unwelcome. Examples of sexual harassment include, but are not limited to, unwelcome sexual advances, request for sexual favours, unwelcome remarks of a sexual nature, jokes about a person's body or sexual orientation, taunting, repeated unwelcome requests for dates, touching or brushing against, hugging, kissing, patting, grabbing, pinching, and displaying sexually oriented printed material or pictures.

RESPONSIBILITIES:

General:

It is the responsibility of all employees to comply fully with the Human Rights Policy. Any employee who wishes clarification of this policy, or is seeking an informal discussion regarding a possible allegation, is encouraged to approach their immediate Supervisor, Industrial Relations, or a member of the Union Civil Rights Committee. All such inquiries will be held strictly in confidence.

Managers and Supervisors:

It is the responsibility of every Manager and Supervisor to monitor and ensure that the work environment is free from all forms of discrimination, including personal and sexual harassment: and to conduct appropriate investigations promptly and confidentially. Managers and Supervisors will carry out corrective actions in accordance with policy guidelines.

Industrial Relations:

Industrial Relations will be the policy administrator. In this role Industrial Relations, with the assistance of the Union Civil Rights Committee, will ensure that the Human Rights Policy is distributed and explained to all existing and new employees, as well as contractors and suppliers. Industrial Relations will track all allegations pertaining to violations of the Human Rights Code and will advise Managers and Supervisors in the investigation and in determining the appropriate administrative and/or disciplinary response.

PROCEDURE :

Any employee who may feel they are being **subjected** to personal or **sexual** harassment shall:

1. Make their objection clearly known to the offender by indicating either verbally or in writing that they are offended by the behavior and that it must stop.

If fearful of reprisal, or if the offended employee has been threatened with reprisals, the employee does not have to confront the harasser, but can take the concerns directly to their Supervisor, Department Manager, Industrial Relations or a Union Civil Rights Committee Representative.

2. Prepare and maintain a written record of the dates, approximate times, nature of the unwelcome behavior and witnesses, if any.

3. Record the incident(s) in writing and file the allegation with their immediate Supervisor, Department Manager, Industrial Relations, or Union Civil Rights Committee Representative.

Any employee who observes a fellow employee being subjected to harassment can:

1. Offer support to the victim.
2. Offer to be a witness on behalf of the victim.

3. Tell the harasser that their conduct is inappropriate and a violation of the Human Rights Policy.

If the unwelcome conduct continues, discuss your observations with the harasser's Supervisor, Department Manager, Industrial Relations or Union Civil Rights Committee Representative.

All allegations of a violation of the Human Rights Code must be reported to Industrial Relations. As the administrator of the policy, Industrial Relations is charged with tracking all Human Rights Violations.

Remember that harassment is a violation of the law and is a serious matter. Implementation of this policy does not prohibit employees from reporting **incident(s)** to the Provincial Human Rights Tribunal.

INVESTIGATION PROCEDURE:

Upon receiving an allegation, the following steps will be taken:

1. Assure the complainant that an objective examination of the allegation will be undertaken immediately.
2. Advise the person alleged to be responsible that an allegation of harassment has been lodged.
3. Interview the complainant and the person(s) alleged to be responsible as soon as possible.

4. Interview any witnesses.
5. Document clearly and completely all findings.
6. Render a decision as soon as possible and advise the parties of any action to be taken.
7. Ensure that all information concerning the case is kept confidential.
8. Complainants and respondents shall be provided with representation during all investigative interviews or at any other time during the proceedings. For bargaining unit members the above shall be interpreted to mean Union representation.

CORRECTIVE ACTION:

A substantiated Human Rights violation will be considered as a serious incident.

1. Personal or Sexual Harassment, involving physical assault, warrants immediate suspension without pay during the investigation period, and if found to be culpable, may be grounds for dismissal.
2. Where the Company deems appropriate, any or all of the following measures may be taken:
 - A written apology.
 - Mandatory counseling.
 - Written warning.
 - Final written warning.

- Suspension.
- Permanent or temporary transfer.
- Demotion.
- Discharge.

If a complaint is unfounded, any income or benefits lost, as a result of suspension, will be reinstated.

Where an allegation is found to be malicious, the accuser will be subject to disciplinary action.

APPEAL:

Any decision regarding a violation of the Human Rights Policy may be appealed to the Manager, Human Resources or his designate. If, in the opinion of the Manager, the allegation should be further pursued, he will appoint an internal or an external investigator. The above procedure does not preclude an employee from filing a formal complaint with the Human Rights Tribunal.

NO REPRISALS:

There shall be no reprisals as a result of pursuing a complaint under this policy.

Where a bargaining unit employee receives disciplinary action or is dismissed as a result of findings in accordance with this policy, such action shall be subject to the grievance procedure in accordance with the collective agreement.

POLICY REVIEW:

The Human Rights Policy will be periodically **reviewed and updated in order that it** may continue to meet the requirements of the work place and Human Rights legislation within the province.

LETTER OF UNDERSTANDING

BETWEEN: Highland Valley Copper
of the First Part

AND: United Steelworkers of America,
Local 7619
of the Second Part

SUBJECT ASSIGNMENT &
REASSIGNMENT

In regards to the application of Article 10, Sub-section 10.17 it is agreed that the provisions to temporarily assign out of line of seniority shall apply to the assignment of tradesmen from one shift to another. The parties agree that the practice of assigning pipefitters to work throughout the property has not been a problem and will continue.

In witness whereof the Parties hereto have executed this Letter of Understanding on the 20th day of January, 2004.

SIGNED ON BEHALF OF:
HIGHLAND VALLEY COPPER

J.M. Piwek, S. Steadman, E.J. Anderson

SIGNED ON BEHALF OF:
UNITED STEELWORKERS OF AMERICA
LOCAL 7619

A. Lukinchuk, J. McCarthy

LETTER OF UNDERSTANDING

BETWEEN: Highland Valley Copper
of the First Part

AND: United Steelworkers of America,
Local 7619
of the Second Part

SUBJECT RECALL OF LAID OFF
EMPLOYEESTO DO
CONTRACT WORK

1. The parties agree that the phrase "**No employees shall be displaced, or laid off, or have their right to recall deferred as a result of contracting out,**" in Article 3.07(e) applies to operations and maintenance work that bargaining unit employees normally perform. This agreement is without prejudice to either Parties' positions with respect to the interpretation of "**or as a result of a contractor's employee(s) performing warranty work.**"
2. The Company agrees that where it has contracted or intends to contract out work and there are employees on layoff who, in the opinion of the Company, are qualified to perform a portion of that contract, even though the whole contract could not be performed by bargaining unit employees because the Company does not have the

manpower, skills, equipment and facilities to do so, the Company will recall qualified laid off employees to perform the portion of the work for which they are qualified where it is practicable to do so.

3. Prior to an application of this letter, the Parties agree to meet and discuss all practical areas of concern that may affect the situation of the laid off employees or the viability to the operation of such application.
4. Any dispute regarding the interpretation or application of this agreement, including whether or not it was practicable to recall laid off employees, or whether or not the opinion of the Company was reasonable, may be referred to arbitration pursuant to the terms of the Collective Agreement as a policy grievance.
5. Where employees are recalled pursuant to this agreement and the work to be performed by the laid off employees is intended to last less than fourteen (14) days, the provisions of Article 9.01, 9.10, 9.11, 9.13 and 10 shall not apply except that the senior qualified employees on layoff shall be recalled in order of seniority.
6. In all cases of work intended to be contracted out, the Parties reaffirm their commitment to the principles set out in Article 3.07 and to the procedures set out in Articles 3.07(c) and 3.07(d).

In witness whereof the Parties hereto have executed this Letter of Understanding on the 20th day of January, 2004.

SIGNED ON BEHALF OF:
HIGHLAND VALLEY COPPER

J.M. Piwek
S. Steadman
E.J. Anderson

SIGNED ON BEHALF OF:
UNITED STEELWORKERS OF AMERICA
LOCAL 7619

A. Lukinchuk
J. McCarthy

LETTER OF UNDERSTANDING

- BETWEEN:** Highland Valley Copper
of the First Part
- AND:** United Steelworkers of America,
Local 7619
of the Second Part
- SUBJECT** HISTORICAL LIST -
ARTICLE 3.07(d)
SUB-SECTION (i)

The Parties have agreed to a list of work as per Article 3.07(d) that has historically been contracted out because of the need for specialized skills, specialized equipment and the lack of facilities. In all cases of work intended to be contracted out, the Parties reaffirm their commitment to the principles set out in Article 3.07 and to the procedures set out in Articles 3.07(c) and 3.07(d).

Further to this, the Parties recognize the essential role communications will play in guaranteeing the success of the committee and every effort will be made to ensure these lines of communication are kept open at all times. In addition, the Parties undertake to educate their principals as to the correct interpretation and application of Article 3.07.

In witness whereof the Parties hereto have executed this Letter of Understanding on the 20th day of January, 2004.

SIGNED ON BEHALF OF:
HIGHLAND VALLEY COPPER

J.M. Piwek
S. Steadman
E.J. Anderson

SIGNED ON BEHALF OF:
UNITED STEELWORKERS OF AMERICA
LOCAL 7619

A. Lukinchuk
J. McCarthy

LETTER OF UNDERSTANDING

BETWEEN: Highland Valley Copper
of the First Part

AND: United Steelworkers of America,
Local 7619
of the Second Part

SUBJECT CONTRACTING OUT
PROCEDURES

In an effort to improve communications and increase the effectiveness of the contracting out committee the parties agree to implement the following procedures.

Long Term Projects

Develop and maintain a project list which will allow for:

- A preview involving the project originator, Company and Union contracting out representatives and at times a consultant. The preview will involve discussions as to the nature of the work to be performed, involvement of Highland Valley Copper employees in the project prior to the contractor (vendor) being chosen, the approximate number of contractor employees, the number of days they will be employed and their union affiliation.

- The issue of a preview number if the work or a portion of the work is to be contracted out
- The **issue of a contracting out notice**
- Project updates
- The tender of the project if contracting out is required

At times the vendor will not have been chosen prior to the issue of contracting out notice. However, the Union agrees this will not be a problem as the union has participated in the preview process.

Unplanned Work Where Contracting Out May be Required

When a situation arises where unplanned work is necessary and will require contracting out the following procedures will be followed:

- The staff employee responsible for the work will contact his Company contracting out representative and provide him with all details

Then the Company contracting out representative, will inform the Union representative about the unplanned work. If he is unable to make contact with a member of the Contracting Out Committee, he will inform the Contracting Out Chairman. If he is unable to make contact, he will call the Union President and failing to contact him, will

notify the Contracting Out Chairman via e-mail.

- The representative will inform the person he has contacted of details of the unplanned work, when it will occur, who will be doing the work, what manpower, skills, equipment and facilities will be involved.

The representative will then ensure that a Contracting Out Incident is issued.

Contracting Out Committee Meetings

Contracting out meetings will follow a regular agenda profile. Both Company and Union contracting out representatives will review issues prior to meeting and come prepared to discuss contracting out issues. The parties will:

- Update the projects list
- Review contracting out projects
- Prepare a plan on how and what to communicate to Highland Valley Copper employees regarding contracting out matters. (i.e., advertise successes etc)
- Where there is a dispute the parties will make every effort to resolve the issue through open discussion and all members will participate.

In witness whereof the Parties hereto have executed this Letter of Understanding on the 20th day of January, 2004.

SIGNED ON BEHALF OF:
HIGHLAND VALLEY COPPER

J.M. Piwek
S. Steadman
E.J. Anderson

SIGNED ON BEHALF OF:
UNITED STEELWORKERS OF AMERICA
LOCAL 7619

A. Lukinchuk
J. McCarthy

January 05, 2004

Mr. T. Yuille
Contracting Out Committee Chairman
U.S.W.A., Local 7619
P. O. Box 5
Logan Lake, B. C.
V0K 1W0

Dear Tom:

**RE: LETTER OF ASSURANCE - NOTICE OF
CONTRACTING OUT DATA BASE**

The company agrees that it will not deny the Union access to the notice of contracting out database and will not collapse the database without prior notification to the Union. The company further agrees that, prior to collapsing the contracting out database, arrangements will be made to ensure that the Union has access to all contracting out notices issued.

Yours truly

R. M. Chenier
Superintendent,
Industrial Relations

LETTER OF UNDERSTANDING

BETWEEN: Highland Valley Copper
of the First Part

AND: United Steelworkers of America,
Local 7619
of the Second Part

SUBJECT VALLEY PIT STABILIZATION
PROJECT

During bargaining the company identified a project called the "Valley Pit Stabilization Project". The company advised the Union that without this project mine life will be shorter than planned. The Company indicated that this project will require more employees than what the current mine plan calls for. The Company acknowledged they currently have no firm numbers as to how many additional employees would be required to complete the project.

Therefore, the Union agrees to meet with the company when the company decides to proceed with the "Valley Pit Stabilization Project". Among other issues that may be considered by the parties, the Union may grant the company relief from the limitations contained in the letter of understanding on, "Recall of laid off employees to do Contract Work", and the restraints contained in the agreement on pre-approved notices on contracting out.

In witness whereof the Parties hereto have executed this Letter of Understanding on the 23rd day of October 2003.

SIGNED ON BEHALF OF:
HIGHLAND VALLEY COPPER

R. J. Killough
R. M. Chenier

SIGNED ON BEHALF OF:
UNITED STEELWORKERS OF AMERICA
LOCAL 7619

S. Hunt
R. Boyce

LETTER OF UNDERSTANDING

- BETWEEN:** Highland Valley Copper
of the First Part
- AND:** United Steelworkers of America,
Local 7619
of the Second Part
- SUBJECT:** PENSION PLAN

The parties agree to meet within 3 months of the signing of a new Collective Agreement and annually thereafter to discuss matters pertaining to pension funding. For such meetings the Company will provide the following:

1. A copy of the most recent pension actuarial valuation, or for those years when the plan is not subject to a valuation, an estimate by the Company's Actuaries of the status of the plan.
2. Highland Valley Copper representatives who are knowledgeable about pension funding issues.

In witness whereof the Parties hereto have executed this Letter of Understanding on the 20th day of January, 2004.

SIGNED ON BEHALF OF:
HIGHLAND VALLEY COPPER

J.M. Piwek
S. Steadman
E.J. Anderson

SIGNED ON BEHALF OF:
UNITED STEELWORKERS OF AMERICA
LOCAL 7619

A. Lukinchuk
J. McCarthy

LETTER OF UNDERSTANDING

- BETWEEN:** Highland Valley Copper
of the First Part
- AND:** United Steelworkers of America,
Local 7619
of the Second Part
- SUBJECT:** SEVERANCE PROVISION

1. Any employee laid off as a result of a restructuring of the Company's operation, or permanent closure of the Company's operation in whole or in part, shall be entitled to severance pay as follows:

Basic: 40 hours pay at the employee's normal hourly rate exclusive of premiums;

Plus: 40 hours pay at the employee's normal hourly rate exclusive of premiums for every complete year of continuous service to a maximum of 1300 hours.

2. Employees will be paid their severance pay when their recall rights expire.

In witness whereof the Parties hereto have executed this Letter of Understanding on the 20th day of January, 2004.

SIGNED ON BEHALF OF:
HIGHLAND VALLEY COPPER

J.M. Piwek
S. Steadman
E.J. Anderson

SIGNED ON BEHALF OF:
UNITED STEELWORKERS OF AMERICA
LOCAL 7619

A. Lukinchuk
J. McCarthy

LETTER OF UNDERSTANDING

- BETWEEN:** Highland Valley Copper
of the First Part
- AND:** United Steelworkers of America,
Local 7619
of the Second Part
- SUBJECT:** WORK FORCE REDUCTION
2004

The Company has identified a need to reduce the workforce by 54 people in 2004. The company and Union have agreed that it is desirable to make this reduction by providing incentives for employees to retire or terminate. The Company reserves the right to limit the number of employees who are able to retire or sever and receive a Retiring Allowance Payment or a Separation Allowance Payment to a maximum of 54. The 54 candidates would be selected on a first come first serve basis with preference according to Company seniority from the following classifications

Mine Ops / Mill Ops.	24
Heavy Duty Mechanics	4
Auto Mechanics	2
Mobile Crane Op.	2
Electricians	5
Welders	4
Millwrights.	4

Warehouseman	2
O&T Administration	2
Mill Technical	1
Carpenter	1
Machinist	3
Total	54

Employees currently on Long Term Disability, (L.T.D.), who would qualify for the "Retiring Allowance" or the "Separation Allowance", must make a choice of one (1) of the following:

- (i) Accepting the increases in the L.T.D. benefits outlined in the October 1, 2003 to September 30, 2006 Collective Bargaining Agreement and foregoing any entitlement to the "Retiring" or "Separation" allowances.
 - (ii) Accepting the "Retiring Allowance" outlined in this Letter of Understanding and foregoing any increases in L.T.D. benefits, if applicable, set out in the Letter of Understanding, "Existing Long Term Disability Recipients".
 - (iii) Accepting the "Separation Allowance" outlined in this Letter of Understanding and foregoing any increases in L.T.D. benefits, if applicable, set out in the Letter of Understanding, "Existing Long Term Disability Recipients".
1. Employees with age and service totalling 84 points, with a minimum of 58 years of age as

of December 31, 2004, will qualify for a retiring allowance in accordance with the following schedule, provided they retire on the earlier of December, 31, 2004 or within 90 days after they first qualify for the allowance. Employees who qualify for this retiring allowance will not qualify for a Separation Allowance.

Age in 2004	Retiring Allowance
65	\$7500
64	\$11000
63	\$14500
62	\$18000
61	\$21500
60	\$25000
59	\$25000
58	\$25000

2. Employees 60 years of age and older who do not qualify for an unreduced pension benefit and who choose to retire or terminate on or before December 31, 2004 will be entitled to a Separation Allowance in accordance with the following schedule. Employees who qualify for this Separation Allowance will not qualify for a Retiring Allowance.

Age in 2004	Separation Allowance
65	\$7500
64	\$11000
63	\$14500
62	\$18000
61	\$21500
60	\$25000

In witness whereof the Parties hereto have executed this Letter of Understanding on the 26th day of January, 2004.

SIGNED ON BEHALF OF:
HIGHLAND VALLEY COPPER

R. J. Killough

SIGNED ON BEHALF OF:
UNITED STEELWORKERS OF AMERICA
LOCAL 7619

R. Boyce

LETTER OF UNDERSTANDING

BETWEEN: Highland Valley Copper
of the First Part

AND: United Steelworkers of America,
Local 7619
of the Second Part

SUBJECT MINE CLOSURE

Effective September 30, 2006 the company and the Union agree that a pension window will be provided at mine closure defined as the shutdown of the Highland Mill following the processing of mine reserves and the clearing of all stockpiles. The pension window will be in effect for the 10-day period concluding with the shutdown of the mill. The window will provide that employees who have age and service totaling 80 with a minimum of 55 years of age will be able to retire with an unreduced pension.

Employees 55 years of age and older who do not have factor 80 will be entitled to take an immediate pension with reductions based on 1/3% per month for each month that their retirement date precedes their early unreduced retirement date.

Employees' 55 years of age with a minimum of 15 years of service will be entitled to bridge benefits reduced by 1/3% per month for each

month that their retirement date precedes their early unreduced retirement date.

The company and the Union agree that employees 55 years of age or older at mine closure will be entitled to severance pay of 40 hours pay per year of service or their base rate of pay to age 65, whichever is less.

Employees less than 55 years of age will be entitled to severance pay at mine closure as follows:

- i) for the first 10 years of employment, 80 hours per year of service.
- ii) for the second 10 years of employment, 60 hours per year of service.
- iii) for service greater than 20 years, 40 hours per year of service.

Examples at mine closure:

- a) employee 54 with 36 years of service - service entitlement is:

$$\begin{aligned} 10 \times 80 &= 800 \text{ hours, plus} \\ 10 \times 60 &= 600 \text{ hours, plus} \\ 16 \times 40 &= \underline{640 \text{ hours. plus}} \\ \text{Total} &= 2040 \text{ hours} \end{aligned}$$

- b) employee 38 with 20 years of service - service entitlement is:

$$\begin{aligned} 10 \times 80 &= 800 \text{ hours, plus} \\ 10 \times 60 &= \underline{600 \text{ hours. plus}} \\ \text{Total} &= 1400 \text{ hours} \end{aligned}$$

- c) employee 55 with 25 years of service -
service entitlement is:
 $25 \times 40 = 1000$ hours

The company and the Union agree that the cost of the Pension Window and the severance Package will be charged against the cost of the agreement which becomes effective on October 1, 2006 and the above provisions are not subject to renegotiation in the above noted collective agreement.

In witness whereof the Parties hereto have executed this Letter of Understanding on the 20th day of January, 2004.

SIGNED ON BEHALF OF:
HIGHLAND VALLEY COPPER

J.M. Piwek
S. Steadman
E.J. Anderson

SIGNED ON BEHALF OF:
UNITED STEELWORKERS OF AMERICA
LOCAL 7619

A. Lukinchuk
J. McCarthy

LETTER OF UNDERSTANDING

BETWEEN: Highland Valley Copper
of the First Part

AND: United Steelworkers of America,
Local 7619
of the Second Part

SUBJECT MODIFIED WORK PROGRAM

The Company and the Union agree to the ongoing development of the Modified Work Centre to complement the existing Disability Management and Entry to the Modified Work Centre and Return to Work Policies.

The Company and the Union acknowledge their commitment to provide an equal opportunity for all employees to access the on site rehabilitation program while they recover from an illness or injury be it job related or not.

The modified work program will provide a meaningful productive employment environment within which, individuals may retain their dignity and respect while rehabilitating from disability or injury that had rendered them incapable of performing their regular work.

The success and accountability of the program will be monitored through cooperative methods to ensure that goals and objectives are being realized.

The economic factors related to nurturing a stronger economic future for all employees by encouraging reduction, re-use, and recycling of mine supplies will form the core for identifying work to be assigned to the modified work centre.

In witness whereof the Parties hereto have executed this Letter of Understanding on the 20th day of January, 2004.

SIGNED ON BEHALF OF:
HIGHLAND VALLEY COPPER

J.M. Piwek
S. Steadman
E.J. Anderson

SIGNED ON BEHALF OF:
UNITED STEELWORKERS OF AMERICA
LOCAL 7619

A. Lukinchuk
J. McCarthy

LETTER OF UNDERSTANDING

- BETWEEN:** Highland Valley Copper
of the First Part
- AND:** United Steelworkers of America,
Local 7619
of the Second Part
- SUBJECT:** CREATION OF JOBS FOR
PEOPLE IN THE MODIFIED
WORK PROGRAM

In accordance with the provisions of Article 19.10 of the Collective Agreement, and recognizing the responsibilities of both the Company and the Union towards disabled employees, the Company and the Union agree that four (4) positions for Tool Crib Attendants in Mill Maintenance be created and filled by employees working in the Modified Work Centre or otherwise assigned to light duty, who have a recognized permanent disability.

- i) The new Tool Crib Attendant position will work on a 4X4 round the clock schedule and four (4) employees from the Modified Work programs will be selected to fill the position in accordance with 19.10 of the Collective Agreement.
- ii) Employees selected to fill the position will be paid wage grade 9 as well as appropriate premiums.

- iii) Employees placed under the provision of 19.10 of the collective agreement will not have "super seniority"; and in the event senior trades people, qualified to perform the tool crib position, are faced with being laid off from the company, they will have the right to bump into the tool crib position.

Should a senior trades person, qualified to perform the tool crib position, be placed in motion and have to bump into a lower paying job, then individuals with less seniority working in the tool crib jobs, created by the modified work program, will have their wages adjusted accordingly.

- iv) If it becomes necessary to fill the new Tool Crib position at some future date, whether on a temporary or permanent basis, the position will be filled by tradesmen who have a mechanical background and a proven disability which prevents them from performing a normal job.
- v) The company reserves the right to assign a Millwright on a temporary basis to fill the new position where there are no suitable candidates out of the Modified Work program until a candidate becomes available, at which

time the Millwright would be returned to his normal duties.

- vi) Employees who are physically fit and suitably qualified to fill a classification under the Collective Agreement, whether via the job posting procedures or via a medical bump (10.13), will not normally be considered as candidates to fill the new Tool Crib position.

- vii) The Tool Crib Attendants will be required to issue and receive tools, maintain and repair tools, arrange for and set up tools and supplies for major maintenance works and other related duties as required.

In witness whereof the Parties hereto have executed this Letter of Understanding on the 20th day of January, 2004.

SIGNED ON BEHALF OF:
HIGHLAND VALLEY COPPER

J.M. Piwek
S. Steadman
E.J. Anderson

SIGNED ON BEHALF OF:
UNITED STEELWORKERS OF AMERICA
LOCAL 7619

A. Lukinchuk
J. McCarthy

LETTER OF UNDERSTANDING

- BETWEEN:** Highland Valley Copper
of the First Part
- AND:** United Steelworkers of America,
Local 7619
of the Second Part
- SUBJECT:** EXISTING LONG TERM
DISABILITY RECIPIENTS

The parties agree that, effective October 1, 2003, those employees in receipt of long term disability benefits under previous Collective Agreements shall have their benefits increased to fourteen hundred dollars (\$1,400) per month.

In witness whereof the Parties hereto have executed this Letter of Understanding on the 20th day of January, 2004.

SIGNED ON BEHALF OF:
HIGHLAND VALLEY COPPER

J.M. Piwek
S. Steadman
E.J. Anderson

SIGNED ON BEHALF OF:
UNITED STEELWORKERS OF AMERICA
LOCAL 7619

A. Lukinchuk
J. McCarthy

LETTER OF UNDERSTANDING

BETWEEN: Highland Valley Copper
of the First Part

AND: United Steelworkers of America,
Local 7619
of the Second Part

SUBJECT EMPLOYEE AND FAMILY
ASSISTANCE PROGRAM

Highland Valley Copper and the United Steelworkers of America, Local 7619, have recognized the need *for* a jointly managed Employee and Family Assistance Program (E.F.A.P.) to assist all employees affected by personal problems. Relevant terms of reference of this joint program are contained in a policy statement.

This Program will be funded in its entirety by the Company and the Union on a 84% and 16 % basis respectively.

In witness whereof the Parties hereto have executed this Letter of Understanding on the 20th day of January, 2004.

SIGNED ON BEHALF OF:
HIGHLAND VALLEY COPPER

J.M. Piwek
S. Steadman
E.J. Anderson

SIGNED ON BEHALF OF:
UNITED STEELWORKERS OF AMERICA
LOCAL 7619

A. Lukinchuk
J. McCarthy

LETTER OF UNDERSTANDING

- BETWEEN:** Highland Valley Copper
of the First Part
- AND:** United Steelworkers of America,
Local 7619
of the Second Part
- SUBJECT:** INSULATED COVERALLS

- 1) The Company agrees to reimburse the cost of insulated coveralls to a maximum of \$120.00 per pair where the purchase of such coveralls is authorized as being necessary by the employee's Foreman, having in mind the nature of the work assignment.
- 2) The Company further agrees that each of these employees shall be reimbursed for a minimum of two (2) pairs of insulated coveralls and they will be replaced only on the basis that the employee provides evidence that a current pair of their coveralls are no longer serviceable.
- 3) The Company will not reimburse for lost or stolen coveralls.
- 4) The Company agrees to cover the cost of laundering coveralls on a weekly basis.
- 5) The parties further agree to develop a security system to ensure safe storage of insulated coveralls.

- 6) Any disagreement as to whether or not the nature of the work assignment requires insulated coveralls will be referred to the OHSC. The Committee will investigate any disputes and resolve any disagreements.

In witness whereof the Parties hereto have executed this Letter of Understanding on the 20th day of January, 2004.

SIGNED ON BEHALF OF:
HIGHLAND VALLEY COPPER

J.M. Piwek
S. Steadman
E.J. Anderson

SIGNED ON BEHALF OF:
UNITED STEELWORKERS OF AMERICA
LOCAL 7619

A. Lukinchuk
J. McCarthy

LETTER OF UNDERSTANDING

BETWEEN: Highland Valley Copper
of the First Part

AND: United Steelworkers of America,
Local 7619
of the Second Part

SUBJECT PAYMENT FOR LOSS TIME
TO ATTEND COURSES

The Company agrees that where it is necessary in the opinion of the employer for an employee(s) to take a course in order to continue to work in his present classification and such course is only available at a time when the employee is normally at work to:

- i) where possible offer work on a different schedule such that the employee can attend the course without losing time
or if that is not possible,
- ii) pay for the working time lost to attend the course.

In witness whereof the Parties hereto have executed this Letter of Understanding on the 20th day of January, 2004.

SIGNED ON BEHALF OF:
HIGHLAND VALLEY COPPER

J.M. Piwek
S. Steadman
E.J. Anderson

SIGNED ON BEHALF OF:
UNITED STEELWORKERS OF AMERICA
LOCAL 7619

A. Lukinchuk
J. McCarthy

LETTER OF UNDERSTANDING

BETWEEN: Highland Valley Copper
of the First Part

AND: United Steelworkers of America,
Local 7619
of the Second Part

SUBJECT OFFICE AND TECHNICAL
CLASSIFICATION

Incumbents in Office and Technical Classifications, where formal technical qualifications have been changed, will be encouraged to achieve the new qualifications. To the extent possible, current incumbents may decline to acquire the new qualifications.

In witness whereof the Parties hereto have executed this Letter of Understanding on the 20th day of January, 2004.

SIGNED ON BEHALF OF:
HIGHLAND VALLEY COPPER

J.M. Piwek
S. Steadman
E.J. Anderson

SIGNED ON BEHALF OF:
UNITED STEELWORKERS OF AMERICA
LOCAL 7619

A. Lukinchuk
J. McCarthy

LETTER OF UNDERSTANDING

- BETWEEN;** Highland Valley Copper
of the First Part
- AND:** United Steelworkers of America,
Local 7619
of the Second Part
- SUBJECT** OFFICE AND TECHNICAL
COMMITTEE

The Company and Union agree to establish a Joint Office and Technical Committee composed of three (3) representatives of the Union, and three (3) representatives of the Company; the committee shall include supervisors and office and technical people who are familiar with and experienced in office and technical work.

The terms of reference of the Committee shall be;

- a) To investigate and study Change as it affects:
 - i) Contemplated system upgrades
 - ii) Office and Technical work assignments
 - iii) Training and upgrading requirements
- b) To make recommendations to the Company and the Union respecting the matters set out in (a) above.

The Co-chairmen of the Office and Technical Committee shall meet and prepare an agenda at least five (5) days prior to any scheduled meeting.

In witness whereof the Parties hereto have executed this Letter of Understanding on the 20th day of January, 2004.

SIGNED ON BEHALF OF:
HIGHLAND VALLEY COPPER

J.M. Piwek
S. Steadman
E.J. Anderson

SIGNED ON BEHALF OF:
UNITED STEELWORKERS OF AMERICA
LOCAL 7619

A. Lukinchuk
J. McCarthy

LETTER OF UNDERSTANDING

- BETWEEN:** Highland Valley Copper
of the First Part
- AND:** United Steelworkers of America,
Local 7619
of the Second Part
- SUBJECT:** MAIL DELIVERY

As part of a comprehensive settlement of a number of grievances and Union/Employee concerns, the company and Union have agreed to the contracting out of the mail pick-up and delivery from and to Logan Lake. The company also has agreed to arrange for and pay the cost of the contracted courier service to pick up and deliver mail to and from the Union's office in Logan Lake.

The parties agree that, in the event there are employees on layoff at some future date, this work being contracted out would be returned to the bargaining unit.

In witness whereof the Parties hereto have executed this Letter of Understanding on the 20th day of January, 2004.

SIGNED ON BEHALF OF:
HIGHLAND VALLEY COPPER

J.M. Piwek
S. Steadman
E.J. Anderson

SIGNED ON BEHALF OF:
UNITED STEELWORKERS OF AMERICA
LOCAL 7619

A. Lukinchuk
J. McCarthy

LETTER OF UNDERSTANDING

BETWEEN: HighlandValley Copper
of the First Part

AND: United Steelworkers of America,
Local 7619
of the Second Part

SUBJECT DIVISION OF WORK:
CONSTRUCTION OF
TAILINGS DAMS

The parties agree that the upstream portion of the dam as referred to in this letter is upstream of the highest point on the outer edge of the top of the dam on the down stream side.

Work associated with producing cycloned sand will be done by Highland Valley Copper bargaining unit employees.

When placing the upstream beach, installing the cyclone clusters, installing the drain lines for the cyclones, the spreading of sand placed by the cyclones and installation of the pipelines feeding the cyclones from the cyclone house will be done by Highland Valley Copper bargaining unit employees.

When placing downstream sand, installing the cyclone clusters, installing the drain lines to the upstream beach and installation of the pipelines

feeding the cyclones from the cyclone house will be done by Highland Valley Copper bargaining unit employees. The installation of the cyclone underflow delivery pipelines and spreading and compacting cycloned sand on the downstream side in cells and the installation of the drain lines/ditches from the cells to the decant ponds will be done with contractor employees.

When placing sand on the top of the dam, where on dam secondary cyclones are not used to place sand, in cells to stockpile the material for Zone "A", the sand feed pipelines from the cyclone house to the cells will be installed by Highland Valley Copper bargaining unit employees, and the work involved in preparing the foundation of the cells, in building the cells, spreading the sand in the cells and installing and raising the drain lines to the upstream beach with the cells will be done with contractor employees.

Work to construct the downstream foundation excavation, the construction of granular filter blankets, the till core of the dam and related development of borrow pits and haul roads *to* access these borrow pits will be done using contractor employees.

Work to maintain downstream decant pond dikes and to excavate slimes from the decant ponds will be done using contractor employees.

Where the pipeline grade from the cyclone house to the dam is constructed from

uncompacted material, it will be built using Highland Valley Copper bargaining unit employees. Where the pipeline grade becomes part of the dam structure and requires compaction then the pipeline grade will be built using contractor employees.

On the abutments of the dam, foundation excavation and the placement of compacted glacial till in seepage control blankets (Zone G) will be constructed using contractor employees.

Access roads mainly used by Highland Valley Copper equipment and personnel will be constructed, repaired and maintained by Highland Valley Copper employees.

All additional access roads required to facilitate the activities of the contractor will be constructed, repaired and maintained by the contractor.

Where a contractor's equipment is required to use an access road that is normally repaired and maintained by Highland Valley Copper employees, the contractor will repair on a day to day basis any damage to the access road where and when necessary for the period of time that his equipment is using the road.

In witness whereof the Parties hereto have executed this Letter of Understanding on the 20th day of January, 2004.

SIGNED ON BEHALF OF:
HIGHLAND VALLEY COPPER

J.M. Piwek
S. Steadman
E.J. Anderson

SIGNED ON BEHALF OF:
UNITED STEELWORKERS OF AMERICA
LOCAL 7619

A. Lukinchuk
J. McCarthy

LETTER OF UNDERSTANDING

BETWEEN: Highland Valley Copper
of the First Part

AND: United Steelworkers of America,
Local 7619
of the Second Part

SUBJECT PRIME TIME VACATION

In the event that a change in vacation schedule results in a vacancy in a prime time period and the number of employees absent are fewer than the maximum number of absent employees which can be accommodated at a given time, then that vacancy will be assigned to the most senior employee applying, under the following conditions:

- i) The vacation time available will be posted on the department bulletin board for seven (7) calendar days prior to being assigned.
- ii) Should the successful applicant have vacation time approved in prime time then he must relinquish that period unless no other employee applies for the vacant period.
- iii) No more than two (2) employees may change their vacation as a result of any cancellation.

The employee who has requested and had his prime time vacation cancelled will have no seniority rights for dates already booked. The employee may use his seniority rights for dates not already booked.

Prime time vacation is any period of time during the year when the amount of vacation applications received exceeds the maximum number of employees allowed off on vacation.

In witness whereof the Parties hereto have executed this Letter of Understanding on the 20th day of January, 2004.

SIGNED ON BEHALF OF:
HIGHLANDVALLEY COPPER

J.M. Piwek
S. Steadman
E.J. Anderson

SIGNED ON BEHALF OF:
UNITED STEELWORKERS OF AMERICA
LOCAL 7619

A. Lukinchuk
J. McCarthy

October 31, 2003

Richard Boyce, President
U.S.W.A., Local 7619
P.O. Box 5
Logan Lake, B.C.
V0K 1W0

RE: LETTER OF ASSURANCE

During collective bargaining the Union raised concerns regarding scheduled time off; the Union inquired whether the assignment of an employee to Temporary Foreman would result in a reduction to the maximum number of employees on a shift or in a group who could then be permitted to schedule time off.

The Company agrees it shall not include those employees performing relief work as temporary foreman when determining the maximum number of employees to be allowed off at any given time.

Yours truly,

R.J. Killough

LETTER OF UNDERSTANDING

- BETWEEN:** Highland Valley Copper
of the First Part
- AND:** United Steelworkers of America,
Local 7619
of the Second Part
- SUBJECT:** ASSAY LABORATORY LINE
OF PROGRESSION

The Company and the Union agree to the establishment of a line of progression for Chemical Technicians in the Assay Laboratory which permits advancement of personnel up to the level of Chemical Technician III based on the attainment of the necessary qualifications and experience.

The qualifications for the various levels of Chemical Technician and for the position of Chemist will be as follows:

Chemical Technician I

- Completed course equivalent to B.C.I.T. Chemical Sciences Technology Diploma

Chemical Technician II

- Completed course equivalent to B.C.I.T. Chemical Sciences Technology Diploma
- One (1) year related work experience

Chemical Technician III

- Completed course equivalent to B.C.I.T. Chemical Sciences Technology Diploma or BC Assayers Certificate or equivalent.
- MS Excel and Database
- Three (3) years related work experience

Chemist

- BC Assayers Certificate or equivalent
- Computer course requirements for Chemical Technician III
- Three (3) years related work experience

For those employed as Chemical Technician II at the date of this letter the educational qualification required to move to Chemical Technician III may be met by completion of chemistry courses Chem 110 and 111 and laboratory courses Chem 115 and Chem 116 offered by the Open Learning Agency (or equivalent). Completion of the two computer courses listed above will also be required.

The Company and the Union agree that the existing flexibility of task allocation in the laboratory which permits any of the routine sample preparation and analysis to be carried out by any of the laboratory personnel will continue.

In witness whereof the Parties hereto have executed this Letter of Understanding on the 20th day of January, 2004.

SIGNED ON BEHALF OF:
HIGHLAND VALLEY COPPER

J.M. Piwek
S. Steadman
E.J. Anderson

SIGNED ON BEHALF OF:
UNITED STEELWORKERS OF AMERICA
LOCAL 7619

A. Lukinchuk
J. McCarthy

LETTER OF UNDERSTANDING

- BETWEEN:** HighlandValley Copper
of the First Part
- AND:** United Steelworkers of America,
Local 7619
of the Second Part
- SUBJECT:** "ON CALL DUTY"
AUTOMATION SYSTEMS -
MILL TECHNICAL GROUP
PROCESS SYSTEMS
TECHNICIANS

The Company and the Union agree to the creation of "On Call Duty" for the mill technical group.

"On Call Duty" is required to cover times where complex automation systems are down or experiencing technical problems and there are no qualified people on site to trouble shoot and or make the required repairs.

- As the work in question has historically been performed by both staff and bargaining unit employees "On Call Duty" will be performed by both staff and bargaining unit employees in the mill technical group who are qualified to do the work.

- The Company will determine the qualifications and the number of employees to be available for "On Call Duty".
- All bargaining unit employees affected by this Letter of Understanding must advise their supervisor in writing if they wish to have their name added to the "On Call Duty" rotation.
- Employees who have agreed to "On Call Duty" must be available by phone and fit for work as per the rotation schedule and remain within one hour travel time of the mine.
- Bargaining unit employees who no longer want to be available for the "On Call Duty" must advise their supervisor in writing, and will remain on the rotation for six (6) months prior to having their name removed.
- Employees wanting to skip their rotation must have their supervisors permission and must seek such permission two (2) weeks in advance.
- Bargaining unit employees will have their names removed from the "On Call Duty" rotation list for the purpose of vacations. Once their block or blocks of vacations are completed their name will be added back into the rotation.

- Compensation will be one hundred and fifty dollars (\$150.00) per seven (7) day "On Call Duty".
- Regular call out rates will be paid when a site visit is required.

The parties agree that this Letter of Understanding shall remain in effect for the duration of the collective agreement unless either party gives thirty (30) days cancellation notice. The Parties further agree that they will not give notice of cancellation for a six (6) month trial period, and during this time agree to discuss and resolve any problems that arise.

In witness whereof the Parties hereto have executed this Letter of Understanding on the 20th day of January, 2004.

SIGNED ON BEHALF OF:
HIGHLAND VALLEY COPPER

J.M. Piwek
S. Steadman
E.J. Anderson

SIGNED ON BEHALF OF:
UNITED STEELWORKERS OF AMERICA
LOCAL 7619

A. Lukinchuk
J. McCarthy

LETTER OF UNDERSTANDING

- BETWEEN:** Highland Valley Copper
of the First Part
- AND:** United Steelworkers of America,
Local 7619
of the Second Part
- SUBJECT:** CYCLONE OPERATORS

The parties agree that Cyclone Operators will be paid a half hour at a rate of time and one-half in recognition for reporting for work at the LL Dam using their own vehicle.

In witness whereof the Parties hereto have executed this Letter of Understanding on the 20th day of January, 2004.

SIGNED ON BEHALF OF:
HIGHLAND VALLEY COPPER

J.M. Piwek
S. Steadman
E.J. Anderson

SIGNED ON BEHALF OF:
UNITED STEELWORKERS OF AMERICA
LOCAL 7619

A. Lukinchuk
J. McCarthy

LETTER OF UNDERSTANDING

BETWEEN: Highland Valley Copper
of the First Part

AND: United Steelworkers of America,
Local 7619
of the Second Part

SUBJECT SHIFT CHANGE PREMIUM
FOR CRUSHER OPERATORS

It is hereby agreed that the Crusher Operators who operate #1, #4 and #5 crushers will change shifts in accordance with the provisions of Article 13.14 and will be entitled to a premium of \$15.00 per shift.

In witness whereof the Parties hereto have executed this Letter of Understanding on the 20th day of January, 2004.

SIGNED ON BEHALF OF:
HIGHLAND VALLEY COPPER

J.M. Piwek
S. Steadman
E.J. Anderson

SIGNED ON BEHALF OF:
UNITED STEELWORKERS OF AMERICA
LOCAL 7619

A. Lukinchuk
J. McCarthy

LETTER OF UNDERSTANDING

- BETWEEN:** Highland Valley Copper
of the First Part
- AND:** United Steelworkers of America,
Local 7619
of the Second Part
- SUBJECT** 1- UTILITYMAN, MILL
OPERATIONS

The parties agree to the creation of a classification of Utilityman Mill Operations on 4x4 days and nights. To hold the classification as Utilityman an employee must be trained and competent to perform the following functions:

- existing shift labourer
- existing leach plant helper
- mix reagents / slake lime
- operate bobcats
- Mill Operator I

In witness whereof the Parties hereto have executed this Letter of Understanding on the 20th day of January, 2004.

SIGNED ON BEHALF OF:
HIGHLAND VALLEY COPPER

J.M. Piwek
S. Steadman
E.J. Anderson

SIGNED ON BEHALF OF:
UNITED STEELWORKERS OF AMERICA
LOCAL 7619

A. Lukinchuk
J. McCarthy

LETTER OF UNDERSTANDING

- BETWEEN:** Highland Valley Copper
of the First Part
- AND:** United Steelworkers of America,
Local 7619
of the Second Part
- SUBJECT** UTILITYMAN / MSU'S
WORKING WITH MILL
MAINTENANCE CREWS

The company and union agree that, when Utilityman or MSU are assigned to work with the Mill Maintenance crews, they will be paid wage grade 5. It's further agreed that the application of this letter will not adversely affect those millwrights currently working on shift.

Principle Responsibilities will be as follows:

- i) Assist maintenance on Mill Lining and Crusher Work provided they have the training to complete the work competently and safely.
- ii) Set up work for the Mill Lining and Crusher crews
- iii) Maintenance clean-up.

In the event that a restructuring of work would result in the lay off or displacement of Millwrights or a Heavy Duty Mechanic out of their trade, the

parties agree to eliminate/restrict the use of Utilityman and MSU's, to perform maintenance activities so that the maximum number of Millwrights and Heavy Duty Mechanics may be retained in their trade.

In witness whereof the Parties hereto have executed this Letter of Understanding on the 22nd day of October 2003.

SIGNED ON BEHALF OF:
HIGHLAND VALLEY COPPER

J. Price
C. Rondestvedt
R. Chenier
E. Anderson

SIGNED ON BEHALF OF:
UNITED STEELWORKERS OF AMERICA
LOCAL 7619

R. Boyce
S. Hunt

LETTER OF UNDERSTANDING

- BETWEEN:** Highland Valley Copper
of the First Part
- AND:** United Steelworkers of America,
Local 7619
of the Second Part
- SUBJECT** BUMPING INTO THE
UTILITYMAN'S POSITION
MILL OPERATIONS AND
FILLING A PERMANENT
VACANCY IN THE
UTILITYMAN'S
CLASSIFICATION

In the event of a work force reduction where employees are placed in motion such employees would be allowed to bump into the utilityman job in the mill operations lines of progression provided they have the company seniority to do so.

As the training period for the utilityman's job *is* lengthy the company would allow eight employees at a time to bump into the utilityman position. Two on each of the continuous shift crews. If there are more than eight employees wanting to bump into the utilityman classification they would be temporarily assigned to D/S to complete their training then move to the utilitymans job on shift within 3 months; during

this period of time they will be paid wage grade 4 and all applicable shift premiums.

Permanent vacancies for Utilityman will be filled from the MSU classification.

In witness whereof the Parties hereto have executed this Letter of Understanding on the 20th day of January, 2004.

SIGNED ON BEHALF OF:
HIGHLANDVALLEY COPPER

J.M. Piwek
S. Steadman
E.J. Anderson

SIGNED ON BEHALF OF:
UNITED STEELWORKERS OF AMERICA
LOCAL 7619

A. Lukinchuk
J. McCarthy

LETTER OF UNDERSTANDING

BETWEEN: Highland Valley Copper
of the First Part

AND: United Steelworkers of America,
Local 7619
of the Second Part

SUBJECT FILLING A PERMANENT
VACANCY AND LATERAL
MOVES IN THE JOB
CLASSIFICATIONS LISTED IN
THE MILL OPERATOR I, II
AND III LINE OF
PROGRESSION

When filling a permanent vacancy in the job classifications listed in Mill Operator I, II or III the company will allow for lateral moves by canvassing the trained operators in Mill Operator I, II or III respectively, depending on where the vacancy exists.

Once the lateral moves are complete the company will fill the remaining vacancy by canvassing the trained operators in the classifications in the line of progression immediately below.

If the vacancy is on another shift, employees may refuse the promotion. If the vacancy is on the same shift, senior trained operators may

refuse the promotion. If the job is still not filled then the company will assign the trained operator from the shift where the vacancy exists with the least company seniority.

In witness whereof the Parties hereto have executed this Letter of Understanding on the 20th day of January, 2004.

SIGNED ON BEHALF OF:
HIGHLAND VALLEY COPPER

J.M. Piwek
S. Steadman
E.J. Anderson

SIGNED ON BEHALF OF:
UNITED STEELWORKERS OF AMERICA
LOCAL 7619

A. Lukinchuk
J. McCarthy

LETTER OF UNDERSTANDING

- BETWEEN:** Highland Valley Copper
of the First Part
- AND:** United Steelworkers of America,
Local 7619
of the Second Part
- SUBJECT:** "LATERAL CREW TRANSFER
REQUEST" - MILL OPERATOR
I, II AND III CLASSIFICATIONS

The parties agree to allow lateral crew transfer requests in order to expedite the lateral moves referred to in paragraph one of the letter of understanding, "Filling a Permanent Vacancy and Lateral Moves in the Job Classifications Listed in the Mill Operator I, II and III Line of Progression" of the collective agreement. This letter shall remain in effect for the duration of the collective agreement.

Employees in the Mill Operator I, II and III classifications who want to laterally change crews will fill out a "Lateral Crew Transfer Request" form. (Copy attached)

When filling permanent vacancies in the Mill Operator I, II and III classifications the Company will check the "Lateral Crew Transfer Requests" for candidates prior to canvassing the trained operators list.

The following will govern lateral crew transfers:

1. "Lateral Crew Transfer Request" forms must be signed by the employee **and** his supervisor.
2. Copies of the signed "Lateral Crew Transfer Request" form will be issued to:
 - the employee
 - the mill operations superintendent
 - all mill operations shift foremen
 - the plant analyst, and
 - a copy will be placed in the employees file.
3. When filling out the "Lateral Crew Transfer Request" form the employee will select:
 - the crew to which he wishes to transfer
 - the position he wishes to fill within his existing classification of Mill Operator I, II or III. These positions are listed in the "Mill Department Operations Lines of Progression" in the Collective Bargaining Agreement.
4. An employee will be able to transfer under the terms of the Letter of Understanding "Filling a Permanent Vacancy and Lateral Moves in the Job Classifications Listed in the Mill Operator I, II and III Line of Progression" if he has followed #2 and has signed up for a crew transfer.

5. An employee must cancel his "Lateral Crew Transfer Request " prior to the shift being awarded or he will be required to accept the crew transfer. Once an employee has canceled his "Lateral Crew Transfer Request" he will not be allowed to sign up again until the 4th of January of the following year.
6. Except as in #7 below an employee who has been awarded a lateral crew transfer will not be eligible to sign up for another lateral crew transfer until January 4th of the following year.
7. Where a vacancy in Mill Operator I, II or III has not been filled and all the lateral moves and job postings have been exhausted then employees affected by #6 above will be eligible to make another lateral move.
8. The company and the Union will hold crew meetings and go over the new format,
9. The parties will meet at the request of either party to resolve all concerns brought forward.

In witness whereof the Parties hereto have executed this Letter of Understanding on the 20th day of January, 2004.

SIGNED ON BEHALF OF:
HIGHLAND VALLEY COPPER

J.M. Piwek
S. Steadman
E.J. Anderson

SIGNED ON BEHALF OF:
UNITED STEELWORKERS OF AMERICA
LOCAL 7619

A. Lukinchuk
J. McCarthy

**"LATERAL CREW TRANSFER REQUEST"
MILL OPERATOR I, II and III**

Name: _____

Payroll #: _____

Job Classification: _____

Department Seniority Date: _____

Request Transfer From __ Crew to **A B C D** Crew
(CIRCLE CHOICE)

To the Position of _____ in

The Mill Operator _____ Classification.

Date: _____

Employee Signature: _____

Supervisor Signature: _____

I Wish to Cancel My Request at this Time

Employee Signature: _____

Supervisor Signature: _____

Date: _____

LETTER OF UNDERSTANDING

BETWEEN: Highland Valley Copper
of the First Part

AND: United Steelworkers of America,
Local 7619
of the Second Part

SUBJECT BUMPING INTO THE MILL
OPERATOR I, II & III

The company and Union agree that where employees have been put in motion through the application of Article 9.10, such employees will be permitted to bump into the classifications of Mill Operator I, II or III provided they previously held a classification referred to in the Wage Grade Qualifications section of the Collective Bargaining Agreement and included in the responsibilities of the Mill Operator I, II or III respectively.

Further the parties agree that to remain in the classification of Mill Operator I, II or III the employee must agree to complete the training on all the assignments in the classification as set out in the Wage Grade section.

In witness whereof the Parties hereto have executed this Letter of Understanding on the 20th day of January, 2004.

SIGNED ON BEHALF OF:
HIGHLAND VALLEY COPPER

J.M. Piwek
S. Steadman
E.J. Anderson

SIGNED ON BEHALF OF:
UNITED STEELWORKERS OF AMERICA
LOCAL 7619

A. Lukinchuk
J. McCarthy

LETTER OF UNDERSTANDING

- BETWEEN:** Highland Valley Copper
of the First Part
- AND:** United Steelworkers of America,
Local 7619
of the Second Part
- SUBJECT** CREATION OF THE "WATER
SEWER TREATMENT
OPERATOR"
MILL OPERATIONS

The parties have agreed to separate the duties associated with the job of Gardener/Water Systems Utilityman. The duties of the gardener will move to the M.S.U. II wage grade qualifications and lines of progression. The duties associated with the Water Systems Utilityman will be included in the work of the new classification of Water Sewer Treatment Operator referred to below.

Water Sewer Treatment Operator

The parties have agreed to create the job classification of Water Sewer Treatment Operator. The Water Sewer Treatment Operator will be paid at wage grade #7 and be entitled to a 15 cent per hour tool allowance. The incumbent will perform all the duties associated with the operation of Highland Valley Copper's

Water and Sewer Treatment Facilities. The incumbent will also perform the maintenance functions for which he is qualified and which are required from time to time to keep the facilities operating.

The parties further agree that one (1) full time back up operator position will be created for the Water & Sewer Treatment Plants and will be paid wage grade 7 no tool allowance. The incumbent will also be required to perform the gardener duties during the winter months and will work from 6 am to 4pm during the winter months in order to prepare walkways etc. for the on coming shift.

The following duties are preventative maintenance:

- Clean the injector probe
- Change chlorine lines going into check valves
- Change out damaged gauges
- Turbidity analyzer - checking & adjusting the sample flow weekly - pull heads clean out both chambers.
- Pre-treatment and clean sample chamber
- Adjustment to back wash - sequence timers maintaining & cleaning chlorine tanks
- Maintaining potassium permanganate pumping system check valves & lines
- Change out lights on control panel

In witness whereof the Parties hereto have executed this Letter of Understanding on the 20th day of January, 2004.

SIGNED ON BEHALF OF:
HIGHLAND VALLEY COPPER

J.M. Piwek
S. Steadman
E.J. Anderson

SIGNED ON BEHALF OF:
UNITED STEELWORKERS OF AMERICA
LOCAL 7619

A. Lukinchuk
J. McCarthy

LETTER OF UNDERSTANDING

BETWEEN: Highland Valley Copper
of the First Part

AND: United Steelworkers of America,
Local 7619
of the Second Part

SUBJECT BACKUP OPERATORS LISTS
FOR THE MILL PRESSURE
WASHER

The Company and the union agree to establish a list of trained back-up operators for the Pressure Washer used by Mill Operations in order to meet the requirements of the department while employees are absent from the workplace.

Initially there will be two back-up operator positions established. The backup operator requirements will be adjusted upwards if more equipment is utilized or downwards if less equipment is utilized. In order to maintain a high level of skill among those backup operators referred to in this letter, the company agrees they shall be rotated on a project by project basis.

The following conditions will apply:

1. The individuals will be chosen from the Mill Operations day shift crew.

2. The employee with the most departmental seniority desiring the position will be given the opportunity to undergo training.
3. The individuals name will be placed on the trained backup operator list after completing 160 hours of training and successfully passing a written test.
4. Employees on the trained backup operators list will be paid their normal wage grade when they are not working with the pressure washer. They will be paid the established Pressure Washer Operator's wage rate when they are working with the pressure washer.
5. An employee whose name is placed on the list must remain on the list for a period of one (1) year, providing that the employee remains on the Mill Operations day shift crew.
6. An employee wanting to give up his trained operator position after being on the list for at least one year, must do so in writing to his foreman. His name will not be removed from the list until another backup operator has been trained.
7. Nothing in this letter of understanding will limit anyone on the trained backup operator list from bidding on or being awarded any other job opening.

8. Any employee who leaves the Mill Operations day shift crew for any reason shall have his name removed from the trained backup operator list.
9. If a full time operator's position becomes available, the position will be offered to the employees on the backup list based on their seniority. The most junior employee on the list must accept the position if it is refused by the more senior employees.
10. When the pressure washer needs to be run on overtime, one of the full time operators must be present at all times for safety reasons. Overtime will be distributed as equitably as circumstances permit among the full time and backup operators.

In witness whereof the Parties hereto have executed this Letter of Understanding on the 20th day of January, 2004.

SIGNED ON BEHALF OF:
HIGHLAND VALLEY COPPER

J.M. Piwek
S. Steadman
E.J. Anderson

SIGNED ON BEHALF OF:
UNITED STEELWORKERS OF AMERICA
LOCAL 7619

A. Lukinchuk
J. McCarthy

LETTER OF UNDERSTANDING

BETWEEN: Highland Valley Copper
of the First Part

AND: United Steelworkers of America,
Local 7619
of the Second Part

SUBJECT PAINTING IN MILL
DEPARTMENT

Further to Article 19.10 of the Collective Bargaining Agreement which provides for accommodation for the purpose of rehabilitation from work or home related injury or illness, the Company and Union agree that painting in and around the Mill provides a meaningful and productive employment opportunity for the employees currently in the Modified Work Program.

Painting will be assigned as follows in order of preference:

1. Mill employees currently on modified duties and working within the Mill Department and whose rehabilitation & work hardening program does not preclude the physical demands of the assignment.
2. Employees working in a modified duty capacity in other operating departments and

whose rehabilitation and work hardening program does not preclude the physical demands of the assignment.

3. Suitable candidate(s) currently employed in the Modified Work Centre.
4. Mill Operations employees in accordance with department seniority.

Modified duty employees assigned to painting in the Mill will remain at the hourly rate last held immediately prior to the accommodation. Employees painting as provided in item #4 above will be paid at wage grade 7.

While a change of shift may be beneficial to carry out the painting at a time convenient to the process, overtime will not normally be paid to employees while *on* modified duties.

Painting normally done as "general maintenance practice" is not affected by this agreement.

In witness whereof the Parties hereto have executed this Letter of Understanding on the 20th day of January, 2004.

SIGNED ON BEHALF OF:
HIGHLAND VALLEY COPPER

J.M. Piwek
S. Steadman
E.J. Anderson

SIGNED ON BEHALF OF:
UNITED STEELWORKERS OF AMERICA
LOCAL 7619

A. Lukinchuk
J. McCarthy

LETTER OF UNDERSTANDING

BETWEEN: Highland Valley Copper
of the First Part

AND: United Steelworkers of America,
Local 7619
of the Second Part

SUBJECT TIMBERMAN / PAINTER

The Company and the Union agree to the creation of a Timberman / Painter classification.

When the incumbent is not Timbering he will be painting. Painting assignments will not be limited to the mill but will be property wide and in any department.

When Timbering the incumbent will be paid wage grade #9 and when painting the incumbent will be paid at wage grade #7.

The letter of understanding "PAINTING IN MILL DEPARTMENT" in the current collective agreement will not be affected by the Timberman/Painter classification.

If the Timberman/Painter is not available the painting will be assigned to an employee within the department who has the ability and is available to do the work. If no one is available a Company contracting out representative will

inform the union of the work as per the Letter of Understanding "Contracting Out Procedures".

The parties further agree to eliminate the painter classification from the collective agreement.

Creating the Timberman/Painter classification will reduce the need to use contractors to perform painting or timbering work and will also provide employees the opportunity to qualify for higher paying jobs.

The Company will provide the incumbent the necessary training to perform the duties of a painter.

In witness whereof the Parties hereto have executed this Letter of Understanding on the 20th day of January, 2004.

SIGNED ON BEHALF OF:
HIGHLAND VALLEY COPPER

J.M. Piwek
S. Steadman
E.J. Anderson

SIGNED ON BEHALF OF:
UNITED STEELWORKERS OF AMERICA
LOCAL 7619

A. Lukinchuk
J. McCarthy

LETTER OF UNDERSTANDING

- BETWEEN:** Highland Valley Copper
of the First Part
- AND:** United Steelworkers of America,
Local 7619
of the Second Part
- SUBJECT:** EQUIPMENT OPERATOR IV &
250 TON CRANE OPERATOR

With the elimination of the 250 ton crane, the parties agree to grandparent the individuals listed below who previously held the positions of Equipment Operator IV or 250 Ton Crane Operator.

Once these employees retire or bid out of their present classification the company will no longer be required to pay wage grade 9 as this language was changed in the 1998 round of bargaining

<u>Equipment Operator IV</u>	<u>250 Ton Crane Operator</u>
Loran Westman	Jim Niven
Brett Nadeau	Wendal Blewett
William Anderson	Pete Verheyen
Dan Valin	Bill Pearson

In witness whereof the Parties hereto have executed this Letter of Understanding on the 20th day of January, 2004.

SIGNED ON BEHALF OF:
HIGHLAND VALLEY COPPER

J.M. Piwek
S. Steadman
E.J. Anderson

SIGNED ON BEHALF OF:
UNITED STEELWORKERS OF AMERICA
LOCAL 7619

A. Lukinchuk
J. McCarthy

LETTER OF UNDERSTANDING

- BETWEEN:** Highland Valley Copper
of the First Part
- AND:** United Steelworkers of America,
Local 7619
of the Second Part
- SUBJECT** START/STOP TIME -
CONTINUOUS SHIFT MILL
MAINTENANCE

The parties agree that those employees in mill maintenance working the twelve hour continuous shift who report to the mill maintenance supervisor will:

- start their shift at 7:00 on the floor on days that there is a mill down.
- start their shift at 7:00 in the welding shop on days where there are no mills down.
- stop time will be 6:45 in the mill at which time they will be allowed to put away their tools and washup.

The parties further agree that these employees will receive a \$10 shift premium

In witness whereof the Parties hereto have executed this Letter of Understanding on the 20th day of January, 2004.

SIGNED ON BEHALF OF:
HIGHLAND VALLEY COPPER

J.M. Piwek
S. Steadman
E.J. Anderson

SIGNED ON BEHALF OF:
UNITED STEELWORKERS OF AMERICA
LOCAL 7619

A. Lukinchuk
J. McCarthy

LETTER OF UNDERSTANDING

- BETWEEN:** Highland Valley Copper
of the First Part
- AND:** United Steelworkers of America,
Local 7619
of the Second Part
- SUBJECT** START/STOP TIMES -
CONTINUOUS SHIFT MILL
MAINTENANCE
ELECTRICIANS &
INSTRUMENT MECHANICS

The parties agree that the Mill Maintenance Electricians and Instrumentation Mechanics working the twelve (12) hour continuous shift who report to the Mill Maintenance supervisor will:

- Do a "face to face" shift exchange at 7 o'clock, in their normally assigned work area (Electrical Shop)
- Sign out with the Mill Maintenance supervisor, prior to doing the shift exchange
- Be free to wash up on their own time following the 7 o'clock shift exchange

The parties further agree that these employees will receive a \$10.00 shift premium.

In witness whereof the Parties hereto have executed this Letter of Understanding on the 20th day of January, 2004.

SIGNED ON BEHALF OF:
HIGHLAND VALLEY COPPER

J.M. Piwek
S. Steadman
E.J. Anderson

SIGNED ON BEHALF OF:
UNITED STEELWORKERS OF AMERICA
LOCAL 7619

A. Lukinchuk
J. McCarthy

LETTER OF UNDERSTANDING

BETWEEN: Highland Valley Copper
of the First Part

AND: United Steelworkers of America,
Local 7619
of the Second Part

SUBJECT VIBRATION READINGS MILL
MAINTENANCE

- The senior tradesman will be trained to do the vibration readings for the Mill. In addition, any tradesman being permanently accommodated and those tradesman assigned to "Light Duty" within the department may be trained. This will be determined by the length of time they are expected to be accommodated.
- A light duty tradesman will normally do the work. However, if a light duty tradesman is not available the work will be done by a tradesman being permanently accommodated or the senior trained tradesman.

In witness whereof the Parties hereto have executed this Letter of Understanding on the 20th day of January, 2004.

SIGNED ON BEHALF OF:
HIGHLAND VALLEY COPPER

J.M. Piwek
S. Steadman
E.J. Anderson

SIGNED ON BEHALF OF:
UNITED STEELWORKERS OF AMERICA
LOCAL 7619

A. Lukinchuk
J. McCarthy

LETTER OF UNDERSTANDING

- BETWEEN:** Highland Valley Copper
of the First Part
- AND:** United Steelworkers of America,
Local 7619
of the Second Part
- SUBJECT:** SUPPORT EQUIPMENT AIR
CONDITIONERS

In recognition of the concern expressed by the Joint Occupational Health, Safety and Environmental Committee, regarding the high temperatures in the support equipment (Graders, Track Dozers and Rubber Tire Dozers) the company agrees that as new support equipment is purchased it will come fitted with air conditioning.

In witness whereof the Parties hereto have executed this Letter of Understanding on the 20th day of January, 2004.

SIGNED ON BEHALF OF:
HIGHLAND VALLEY COPPER

J.M. Piwək
S. Steadman
E.J. Anderson

SIGNED ON BEHALF OF:
UNITED STEELWORKERS OF AMERICA
LOCAL 7619

A. Lukinchuk
J. McCarthy

LETTER OF UNDERSTANDING

BETWEEN: Highland Valley Copper
of the First Part

AND: United Steelworkers of America,
Local 7619
of the Second Part

SUBJECT BACKUP LISTS - MINE
OPERATIONS

1. In addition to the backup lists as set out in Article 22.24, there is established a Shovel, Rotary Drill and Cableman Operators' backup list. The Shovel Operators, Rotary Drill Operators and Cableman have designated their preferred position should their equipment not be operable due to mechanical difficulty or the Company choosing not to operate that piece of equipment. Each operator must choose either Dozer, Grader, F.E.L. or Cableman so long as they are qualified. Otherwise, their alternate operating assignment will be Haul Truck Driver. Any new Shovel Operator, Rotary Drill Operator or Cableman shall make their choice upon being awarded the new position.
2. In the event a backup operator is required, a selection will be made from the crew's backup lists. If the senior operator is

selected from the Shovel Operator, Drill Operator or Cableman list he will operate that piece of equipment until his regular equipment is available. Should the backup operator be selected from the trained backup operators list as referred to in Article 22.24, the employee next in line on that list in accordance with Article 22.25 will be required to take that position for the remainder of the shift. Such employee shall remain in that position as long as the equipment is operable and shall otherwise be assigned as a Haul Truck Driver.

3. A Blaster Operator or Equipment Operator, who successfully bids from a dayshift position onto a trained operators list, pursuant to Article 22.24, which requires an assignment to a continuous shift schedule, shall receive the requisite training and subsequently be assigned to that shift as a truck driver until he moves up in his line of progression or successfully bids on another position.
4. If a full time operator's position becomes available, the position will be offered to the most senior employee on the backup list for that classification. If the vacancy is on another shift, the employee may refuse the promotion. If the vacancy is on the same shift, the most senior employee on the trained backup operators list on that shift must accept the job.

In witness whereof the Parties hereto have executed this Letter of Understanding on the 20th day of January, 2004.

SIGNED ON BEHALF OF:
HIGHLAND VALLEY COPPER

J.M. Piwek
S. Steadman
E.J. Anderson

SIGNED ON BEHALF OF:
UNITED STEELWORKERS OF AMERICA
LOCAL 7619

A. Lukinchuk
J. McCarthy

LETTER OF UNDERSTANDING

- BETWEEN:** Highland Valley Copper
of the First Part
- AND:** United Steelworkers of America,
Local 7619
of the Second Part
- SUBJECT** EQUITABLE DISTRIBUTION
 OF OVERTIME MINE
 OPERATIONS

The parties agree that there have been times when the amount of overtime available in Mine Operations has gone well beyond that which is normally available on an "Incidental Overtime" basis. At times Mine Operations has had to introduce "Campaign Overtime" measures.

Incidental Overtime;

Is available when there is a need to work overtime to cover for budgeted manpower levels. Examples of this are when there are manpower shortages because employees are away from work due to sickness, leave of absence, weekly indemnity, long term disability, vacation etc.

Campaign Overtime;

Is available when the budgeted manpower level does not enable the mine to meet production requirements. An example of this is when the

planned strip ratio can not be maintained and waste removal falls behind. This will require the mine to operate more than the budgeted amount of trucks resulting in an abnormal amount of overtime.

The following procedures will be implemented in order to ensure the equitable distribution of overtime during times when it is necessary to apply "Campaign Overtime" measures.

PROCEDURE - "CAMPAIGN OVERTIME MEASURES"

- The Superintendent of Mine Operations or his designate will inform the Union President or his designate prior to applying "Campaign Overtime" measures.
- All Mine Operation employees who are qualified to drive truck will be eligible for this overtime.
- The "Incidental Overtime" hours worked will be included with the "Campaign Overtime" hours worked to ensure that all overtime hours worked are balanced as equitably as possible.
- The parties will meet with representatives from Mine Operations and arrange a method of recording the overtime hours worked and the distribution of the overtime that is in the

spirit of Article 13.12 (a) and (b) of the C.B.A.

- Campaign overtime will not be put into effect in **the event of that truck drivers have been put in motion and have not been recalled.**

In witness whereof the Parties hereto have executed this Letter of Understanding on the 20th day of January, 2004.

SIGNED ON BEHALF OF:
HIGHLAND VALLEY COPPER

J.M. Piwek
S. Steadman
E.J. Anderson

SIGNED ON BEHALF OF:
UNITED STEELWORKERS OF AMERICA
LOCAL 7619

A. Lukinchuk
J. McCarthy

LETTER OF UNDERSTANDING

- BETWEEN:** Highland Valley Copper
of the First Part
- AND:** United Steelworkers of America,
Local 7619
of the Second Part
- SUBJECT:** M.I.S. LINES OF
PROGRESSION CHANGES

The parties agree that in the event employees in the classifications of Systems Analyst, Network Analyst or System Support Technician are put in motion under the terms of Article 9.10, they would be allowed to bump into the Accounting Analyst I, Materials Analyst I or Plant Analyst classifications. If an employee moves as set out above, he will have to complete level 1 and level 2 in a recognized accounting course or PMAC in order to advance to Accounting Analyst II or Materials Analyst II respectively. However, such employee may chose not to take further courses and remain at the level of Accounting Analyst I, Materials Analyst I or Plant Analyst.

In witness whereof the Parties hereto have executed this Letter of Understanding on the 20th day of January, 2004.

SIGNED ON BEHALF OF:
HIGHLAND VALLEY COPPER

J.M. Piwek
S. Steadman
E.J. Anderson

SIGNED ON BEHALF OF:
UNITED STEELWORKERS OF AMERICA
LOCAL 7619

A. Lukinchuk
J. McCarthy

LETTER OF UNDERSTANDING

- BETWEEN:** Highland Valley Copper
of the First Part
- AND:** United Steelworkers of America,
Local 7619
of the Second Part
- SUBJECT** CO-OP STUDENT PROGRAM
MANAGEMENT INFORMATION
SYSTEMS (M.I.S.)

The parties have agreed to the implementation of a co-op student program in the Management Information Systems section of the Administration Department. The program will allow existing bargaining unit M.I.S. employees to work on projects while a co-op student will gain work experience performing the duties of a System Support Technician.

The parties have agree that:

The employment of the co-op student shall be four months. (January -April, May - August or September - December) Expiry of the period will be reasonable and just cause for termination.

- In the event of a lay-off the co-op student working in M.I.S will be laid off before any full time M.I.S. employee.

The Company will not reduce the number of full time employees in M.I.S. in favour of employing a co-op student.

- Students must be enrolled in a recognized Co-operative Education program and will be assigned to an area where the work is structured to provide learning experience consistent with their discipline.
- Students in the first or second work term of their Co-operative Education program will be paid wage grade #2 and those in the third work term or beyond will be paid wage grade #3.

In witness whereof the Parties hereto have executed this Letter of Understanding on the 20th day of January, 2004.

SIGNED ON BEHALF OF:
HIGHLAND VALLEY COPPER

J.M. Piwek
S. Steadman
E.J. Anderson

SIGNED ON BEHALF OF:
UNITED STEELWORKERS OF AMERICA
LOCAL 7619

A. Lukinchuk
J. McCarthy

LETTER OF UNDERSTANDING

- BETWEEN:** Highland Valley Copper
of the First Part
- AND:** United Steelworkers of America,
Local 7619
of the Second Part
- SUBJECT** MOVEMENT BETWEEN
ACCOUNTING ANALYST I,
MATERIALS ANALYST I, AND
PLANT ANALYST LINES OF
PROGRESSION.

The parties agree that incumbents in the classifications of Accounting Analyst I, Materials Analyst I and Plant Analyst will be able to move laterally to fill vacancies in any of these classifications, and will be permitted to bump into any of these classifications if they are put in motion under the terms of Article 9.10. If an employee moves as set out above, he will have to complete the level 1 and level 2 in a recognized Accounting course or PMAC in order to advance to Accounting Analyst II or Materials Analyst II respectively. However, such employee may choose not to take further courses and remain at the level of Accounting Analyst I, Materials Analyst I or Plant Analyst.

In witness whereof the Parties hereto have executed this Letter of Understanding on the 20th day of January, 2004.

SIGNED ON BEHALF OF:
HIGHLANDVALLEY COPPER

J.M. Piwek
S. Steadman
E.J. Anderson

SIGNED ON BEHALF OF:
UNITED STEELWORKERS OF AMERICA
LOCAL 7619

A. Lukinchuk
J. McCarthy

LETTER OF UNDERSTANDING

- BETWEEN:** Highland Valley Copper
of the First Part
- AND:** United Steelworkers of America,
Local 7619
of the Second Part
- SUBJECT:** CREATION OF THE RELIEF
PLANT ANALYST AND
REMOVAL OF THE PLANT
ANALYST HUMAN
RESOURCES

The parties agree to create the job of Relief Plant Analyst and fill it using the posting procedures of article 10 of the collective bargaining agreement.

The successful applicant will relieve the plant analysts in the Mine, Mill and Administration departments. The incumbent will also at times be assigned to a department to help out with heavy work loads, otherwise he/she will be assigned to the Mill.

Temporary vacancies, which can not be covered by the Relief Plant Analyst will be posted as per article 10.12 of the C.B.A.

The parties also agree to delete the job of Plant Analyst Human Resources which was created in

the letter of understandingsigned by the parties on September 6, 2001. The duties performed by the Plant Analyst Human Resources were formerly shared by bargaining unit members and staff and will now be performed solely by staff.

Further to this agreement the Company will transfer Carole Lloyd, who held the job of Plant Analyst Human Resourcesto the Mill where she will become a Plant Analyst in Mill Maintenance.

In witness whereof the Parties hereto have executed this Letter of Understanding on the 20th day of January, 2004.

SIGNED ON BEHALF OF:
HIGHLAND VALLEY COPPER

J.M. Piwek
S. Steadman
E.J. Anderson

SIGNED ON BEHALF OF:
UNITED STEELWORKERS OF AMERICA
LOCAL 7619

A. Lukinchuk
J. McCarthy