



# AGREEMENT

between

**ST. LAWRENCE CEMENT, INC.  
MISSISSAUGA PLANT**

and

**UNITED CEMENT, LIME  
GYPSUM AND ALLIED WORKERS'  
INTERNATIONAL UNION  
A.F.L.-C.I.O., C.L.C.  
LOCAL 366**

OCTOBER 1, ~~1993~~<sup>1991</sup>

## INDEX

Article	Page
1 Purpose/Management Rights .....	1
2 Discrimination .....	2
3 Hours of Work and Overtime .....	3
Call-in .....	6
4 Statutory Holidays .....	9
5 Vacations with Pay .....	11
6 Wage Rates .....	14
7 Seniority of Service .....	15
8 Lay-Off Procedure .....	22
9 Plant Committee, Grievance Procedure, and Arbitration .....	23
10 Leave of Absence .....	26
11 Jury Duty and Bereavement .....	28
12 Strikes and Lockouts .....	29
13 Compulsory Check Off .....	29
14 Contract Work .....	30
15 Group Life Insurance, Sickness, and Disability Plan .....	32
16 Classifications and Wage Scales .....	34
Trade Appendix .....	36
Apprenticeship Program .....	37
16.03 Maintenance Items .....	41
16.04 Yard Crew Items .....	41
16.05 C.O.L.A. ....	42
16.06 Bag Bonus .....	43
17 Pension Plan .....	44

<b>18 Security Plan</b> .....	<b>45</b>
<b>19 Health and Safety</b> .....	<b>45</b>
<b>20 Clothing</b> .....	<b>4</b>
<b>21 Duration</b> .....	<b>4</b>
<b>22 Temporary and Permanent Discontinuance</b> .....	<b>6</b>
Appendix A — Training	
Shift Helper .....	51
Console Operator .....	52
Appendix B	
Modes of Production Operation .....	54
Utility Group .....	56
Appendix C	
<b>Shift Schedule</b> .....	<b>57</b>
Letters of Intent .....	65
Technological Change .....	68
Pension .....	69
Appendix D	
Shift Times Tables .....	70
Seniority List .....	79

THIS AGREEMENT made and entered into by and BETWEEN:

ST. LAWRENCE CEMENT, INC.  
MISSISSAUGA, ONTARIO

Hereinafter called the "Company"  
PARTY OF THE FIRST PART  
and

CEMENT, LIME, GYPSUM AND ALLIED WORKER'S  
DIVISION OF BROTHERHOOD OF BOILERMAKERS,  
IRON SHIP BUILDERS, BLACKSMITHS, FORGERS  
AND HELPERS. AFL-CIO-CFL

Hereinafter called the "Union"  
PARTY OF THE SECOND PART

#### ARTICLE 1 – PURPOSE

1.01 – The intention of this Agreement is to provide and improve industrial and economic relationships between St. Lawrence Cement, Inc. and its hourly paid employees, at its **Mississauga** Plant, Ogden Point Quarry and Cement Distributing Depots, represented by the Cement, Lime, Gypsum and Allied Worker's Division of Brotherhood of Boilermakers, Iron Ship Builders, Blacksmiths, Forgers and Helpers. **AFL-CIO-CFL**. It is understood by both parties that their object is the protection of the best interests of the St. Lawrence Cement, Inc. and its employees. Both will abide by this Agreement and all mutual understandings, it being their purpose to settle all differences without disturbance to industrial peace.

1.02 – The Company **recognizes** the Union as the sole collective bargaining agency for its own employees, as mentioned above. The term "employee" or "employees" as and wherever used in this Agreement shall include all

production, maintenance, and laboratory employees but exclude office and laboratory personnel remunerated by monthly salaries, and foremen and persons above the rank of foreman.

### **1.03 -- Reservation of Management Rights**

The union acknowledges that it is the exclusive function of the Employer to:

- (a) Maintain order, discipline and efficiency
- (b) Hire, discharge, direct, demote, suspend or otherwise discipline employees, subject to the provisions of Article 6 and 7.
- (c) Generally to manage the industrial enterprise in which the Employer is engaged and, without restricting the generality of the foregoing, to determine the operation, extension, limitation, curtailment and cessation of operations, the kinds and locations of machines, tools and equipment to be used, the right to study or introduce new or improved methods or facilities.
- (d) The right to establish and maintain reasonable rules and regulations covering the operation of the Employer's business, any violations of which shall be among the causes for discharge.
- (e) Initiate and deal with other matters not otherwise specifically referred to in this Agreement.

**1.04 --** The Employer agrees that these functions will be exercised in a manner consistent with the provisions of this Agreement.

## **ARTICLE 2 -- DISCRIMINATION**

**2.01 --** There shall be no discrimination or intimidation by foremen, superintendents or other agents of the Company

against any employee because of the employee's membership in the Union or by virtue of holding office in the Union.

**2.02** — The Union agrees that no intimidation or coercion shall be **practiced** among the Company's **employees** in recruiting membership of the Union or for other purposes, and that there shall be no soliciting of membership, distribution of propaganda or transaction of any business of the Union on the Company's time or property save such as is **authorized** by this Agreement.

The foregoing shall not be held to restrict or interfere with the right of individual employees to converse freely with each other upon matters of interest to them during rest periods, lunch hour and like interludes.

**2.03** — The Company and the Union agree that they will not discriminate against any employee because of race, religion, faith, creed, age, colour, sex or national origin.

### **ARTICLE 3 – HOURS OF WORK AND OVERTIME**

#### **DAY WORKERS:**

**3.01** — The standard work week shall be one of five **(5)** consecutive days at eight **(8)** hours each, starting at **00:01** Monday, this is not a guarantee of work for any employee for such hours or any other hours.

**3.01.B** — Saturday work for the day workers will be paid at one and one half **(1½)** hourly rate for the first ten **(10)** hours and two **(2)** times hourly rate for all hours over ten **(10)**, exclusive of lunch period.

**3.01.C** — Sunday work for day workers will be paid at two **(2)** times hourly rate for the first ten **(10)** hours and three **(3)** times hourly rate for all hours over ten **(10)** hours, exclusive of lunch period.

FOUR SHIFT OPERATION:

**3.02** — In regards to “Four Shift Operation Personnel” their work will start at **00:01** on the first day of their work (shift) schedule appendix C of the collective agreement.

**3.02.B** — Sunday work for shift workers will be paid at two **(2)** times hourly rate for the first ten **(10)** hours and three **(3)** times hourly rate for all hours over ten **(10)** hours.

**3.02.C** — Shift workers work five **(5)** consecutive days after which they will be off for fifty-six **(56)** hours.

**3.03** — Overtime shall be divided equitably among employees performing a similar **class** of work over each three month period.

**3.03.1** — Overtime refused will be counted as overtime performed on various department overtime sheets. Calculation on hours paid. Overtime sheets shall be given to the Union at the end of each three month period and any inequity shall be corrected in the following three month period, provided that failure to do so will allow filing of a grievance for payment of overtime not equally divided.

**3.03.2** — Overtime offered and not worked shall be charged as if worked. Employees on leave of absence, sick leave, Workers Compensation, lay-off, vacation, shall be charged with overtime occurring in their absence. In the case of phone calls home, the individual to be charged if an adult answers the phone and, the employee is not available, or if there is no answer.

**3.03.3** — During transfer relief employees must be asked for normal overtime in their regular department and may be asked in their transferred department if regular employees refuse. All overtime hours worked by employees in their own department will be recorded on their regular departments overtime record. New employees or employees posting into a new department, shall be credited with the highest of the overtime of their department (or group-to which they are assigned plus one **(1)** hour).

**3.03.3B -- Re: Boatloading and Unloading**

When additional employee(s) are required for Boatloading or Unloading, the Company will attempt to cover the situation with available employee(s) at work at the time.

If overtime is required the regular Boatloaders will be given first opportunity to work.

**3.03.4 --** Work in excess of eight (8) hours in any day or shift shall be deemed overtime. Overtime shall be paid for at the rate of time and one half, up to ten (10) hours and double time for all hours over ten (10) exclusive of lunch period, provided that both daily and weekly overtime shall not be paid for the same hours.

**3.03.5 --** An employee who works overtime shall not be required to take time off to offset such overtime.

**3.04 --** For the purpose of this Agreement, a day shall be considered as a twenty-four (24) hour period, for all hourly paid employees, beginning at 00:00 hours and ending at 24:00 hours, and the week shall be considered as forty (40) working hours.

<b>3.04.1</b>	<b>STARTING TIMES</b>
<b>IPT</b>	<b>0000 0700 0730 0800 1100 1500 1530 1600</b>
<b>Packing Plant</b>	<b>0000 0700 0730 0800 1100 1500 1530 1600</b>
<b>Maint. Garage</b>	<b>0000 0700 0730 0800 1500 1530 1600</b>
<b>Maint. Quarry</b>	<b>0000 0700 0730 0800 1500 1530 1600</b>
<b>Maint. Yard</b>	<b>0000 0700 0730 0800 1500 1530 1600</b>
<b>Mech. and Elec.</b>	<b>0000 0700 0730 0800 1500 1530 1600</b>
<b>Prod. Shift</b>	<b>0000 0800 1600</b>
<b>10 Hr. Shifts</b>	<b>0600 0700 0800 1200 1600</b>
<b>12 Hr. Shifts</b>	<b>0700 0800 1900 2000</b>

In regard to four shift operation personnel, the week shall start at 00:00 hours, on the first day of their scheduled work week. (see Appendix C, Shift Schedule).



**3.04.2** — Any deviation from these starting times shall be considered and treated in accordance with provisions of Article 3.05.1 or 3.07.

**3.04.3** — Monday to Friday hours worked between **8:00** am -**16:00** pm for non job related training **ie.** safety or company programs will be paid at the employees regular straight time hourly rate.

**3.04.4** — Any employee who has not been notified not to come to work and reports to work shall be paid four **(4)** hours at straight time. If he commenced to work and works any portion of his normal shift, he shall be paid eight **(8)** hours straight time.

**3.05.1** — CALL IN — When an employee is instructed to report to work during any hours in addition to his regular work, except immediately before or following his regularly scheduled hours, or he is notified at least twelve **(12)** hours in advance of his normal starting time to report to work, whether called at home or asked at work, a minimum four **(4)** hours time shall be paid for such emergency calls at the rate of one and one half **(1½)** times his regular rate for the **first** two **(2)** hours; double **(2)** time to be paid for the next two **(2)** hours. Double **(2)** time to be paid for four **(4)** hours for a second emergency call-in in a day, **00:00-24:00** hours.

**3.05.2** — The purpose of call-in work is to have work performed which is urgently required at that time. The first job performed will be paid as a call-in. Additional jobs performed during a call-in will be paid for according to additional time or a minimum of one **(1)** hour each at the applicable overtime rate.

**3.05.2B** — The Company will advise the employee as to the nature of work to be done.

**3.05.2C** — Call-in will not be used for production shift coverage, **ie.** absenteeism, due to illness, **WCB**, lateness or vacation.

**3.05.2D** – When a second crew is required on a continuous basis, for the same emergency, it will be treated and paid for as a call-in.

**3.05.2E** – When a third crew is required on a continuous basis, for the same emergency, call-in rates will not apply. This crew will be paid at the applicable overtime rate.

**3.05.2F – UNSCHEDULED WEEKEND OVERTIME**  
When employees are called at home (except during the hours of 11:00 pm Friday - 7:00 am Saturday and 11:00 pm Saturday - 7:00 am Sunday) and offered overtime on Saturday or Sunday, this will not be considered call-in and will be paid at the applicable overtime rates.

**3.05.3** – Call-in work extending over 24:00 hours on Sunday to be paid at applicable rate.

**3.06** – Any employee who has not been notified, not to come to work and reports to work shall be paid four (4) hours at straight time. If he commenced to work and works any portion of his normal shift, he shall be paid eight (8) hours straight time.

**3.06.1** – Shift work to be equalized as much as possible in all day worker departments.

**3.06.2** – If any work is done during shutdown periods, such work is to be equally distributed among employees insofar as it is practical to do so.

**3.07** – The Company agrees to post the change in shift (day, afternoons, midnights) for all employees two (2) days or forty-eight (48) hours in advance of new starting time in case of breakdown or emergency situation. Time and one half will be paid for the first day of schedule during the normal week if notification is not given. Double time will be paid for the first day of a schedule if notification not given, providing that the first working day of the schedule is on Sunday.

3.08.1 – Meal allowance to be paid at the following rates:  
October 1, 1991 \$7.00  
Per the following conditions.

3.08.2 – To an employee who works more than ten (10) consecutive hours scheduled or unscheduled and at the end of every four (4) consecutive hours worked thereafter, except the last.

3.08.3 – To an employee who is called out and works more than four (4) consecutive hours as well as after every four (4) consecutive call out hours worked thereafter, except the last.

3.09.1 – Each employee shall be given a ten (10) minute rest break with pay, in each half of their shift. Such break shall be given where possible at the midway point in each half shift. Each employee shall be given a five (5) minute wash-up period, with pay, at the end of each shift, during which time employees will be allowed to leave.

3.09.2 – Employees working on regular continuous operating jobs must remain on their job until relieved by their replacement, or he has informed the supervisor, and he shall be released by the supervisor providing the release of such employee will not interfere with the continuous and safe operation of the plant.

3.10.1 – Should an employee, other than shift personnel, be required to work through their lunch period, they shall be entitled to a twenty (20) minute lunch break to be consumed as soon as the emergency work is over and be paid thirty (30) minutes at overtime rate or he may choose to punch out after eight (8) hours of work and receive full payment for the full eight (8) hours. Shift personnel will be allowed their twenty minute break when operating conditions permit.

3.10.2 – Whenever twelve (12) hour shifts are in effect, the starting time shall be 07:00, 08:00 hours or 19:00, 20:00 hours and the employees shall have a twenty (20) minute lunch

time, with pay, in addition to the provisions of 3.08.1. Lunch period to be given between fourth and fifth hours.

#### **ARTICLE 4 – STATUTORY HOLIDAYS**

**4.01.1 –** Employees covered by this agreement will be entitled to eight (8) hours regular pay for any of the Statutory Holidays provided:

The employees worked their regular shift or work hours on the work day immediately preceding and succeeding the holiday observed or was absent for the following reasons:

- (1) Illness, substantiated by proper medical documentation, lay-off, Worker's Compensation Board illness or other leave of absence properly granted by the Company, provided the employee has worked within the thirty (30) day period immediately preceding the holiday; or
- (2) serving on Jury Duty; or
- (3) other reason acceptable to the Company.

**4.01.2 –** Probationary employees must have completed, immediately prior to the holiday, sixty (60) days continuous employment with the Company.

**4.02.1 –** Paid statutory holidays shall be:

New Year's Day  
Third Monday in February (until such time as the government properly designates a new statutory holiday).  
Good Friday  
Victoria Day  
Canada Day  
Civic Holiday  
Labour Day  
Thanksgiving Day  
Christmas Eve  
Christmas Day  
Boxing Day  
New Year's Eve

**4.02.2** — If any of the above holidays fall on a Saturday or a Sunday, the following Monday shall be observed and paid for as the holiday, providing that if December 24, 25, 26, and 31, and January 1 fall on a Saturday or Sunday, by mutual agreement between the Company and the Union, any of these holidays may be observed on any other work day.

**4.02.3** — Double time and one half (2½) will be paid for all time worked up to eight (8) hours on a Statutory Holiday. All hours worked in excess of eight (8) hours on a Statutory Holiday will be paid at the rate of triple time and one half (3½). Double time shall be paid for all hours worked on a Statutory Holiday by probationary employees who have not completed, prior to the Statutory Holiday, sixty (60) calendar days of employment. Work performed other than during an employee's regular shift or working hours, on a Statutory Holiday will be paid at the rate of triple time and one half (3½) the regular rate.

**4.03** — When any of the said holidays fall during the employee's vacation, they shall receive one (1) extra day or days full pay in addition to their regular vacation. The employee must take one (1) additional day off at the beginning or at the end of their vacation for each holiday occurring during their vacation period. The employee shall have the right to select such day(s) provided that they give notice to the Company on the day their vacation is confirmed, otherwise the Company shall have the right to select such day(s). If such employee is requested to work and they work, such work shall be deemed and paid as contemplated in 4.02.3. On the present four (4) shift operation, if a Statutory Holiday(s) fall on an employee's scheduled day(s) off, the employee's first scheduled shift(s) at regular rate following the Statutory Holiday(s) shall be observed and paid for as the holiday(s) instead of the actual holiday(s).

**4.04** — The Company agrees that although the manufacture of cement requires that operations be continuous, it will reduce operating personnel to a minimum, which in the

opinion of the Management is required to maintain operating continuity on the above holidays.

4.05 — The Company shall post the notice of those employees who are to work on the holiday at least three (3) working days prior to such holiday.

#### ARTICLE 5 — VACATIONS WITH PAY

5.01.1 — Vacation will be taken on a calendar year basis effective January 1. Calendar year is the year when the employee started to be employed by the Company, i.e., date of hiring August 1978, first calendar year is 1978.

5.01.2 — During the first calendar year of employment, vacation will be earned at the rate of one (1) day per month of employment to a maximum of ten (10) working days. This vacation may be taken at any time during the second calendar year.

5.01.3 — After the completion of the second calendar year, the employee may take his earned two (2) weeks vacation at any time during the third calendar year. The two (2) weeks will be paid at the rate of eighty (80) hours at regular time for non-shift workers, and at the rate of eighty-four (84) hours at regular time for shift workers or four (4) per cent of gross wages earned during the previous calendar year in accordance with the Statement of Remuneration paid (T-4 Slips, Box 14) filed by the Company, whichever is greater.

5.01.4 — After the completion of the fourth calendar year, the employee will be entitled to three (3) weeks of earned vacation which may be taken at any time during the fifth calendar year. The three (3) weeks of vacation will be paid at the rate of one hundred and twenty (120) hours at regular time for non-shift workers and at the rate of one hundred and twenty-six (126) hours at regular time for shift workers or six (6) per cent of gross wages earned during the

previous calendar year in accordance with the Statement of Remuneration paid (T-4 Slips, Box 14) filed by the Company, whichever is greater.

5.01.5 – After the completion of the eighth calendar year, the employee will be entitled to four (4) weeks of earned vacation which may be taken any time during the ninth calendar year. The four (4) weeks vacation will be paid at the rate of one hundred and sixty (160) hours at regular time for non-shift workers and at the rate of one hundred and sixty-eight (168) hours at regular time for shift workers or eight (8) per cent of gross wages earned during the previous calendar year in accordance with the Statement of Remuneration paid (T-4 Slips, Box 14) filed by the Company, whichever is greater.

5.01.6 – After the completion of the eighteenth calendar year, the employee will be entitled to five (5) weeks of earned vacation which may be taken at any time during the nineteenth calendar year. The five (5) weeks will be paid at ten (10) per cent of gross wages earned during the previous calendar year in accordance with the Statement of Remuneration paid (T-4 Slips, Box 14) filed by the Company, whichever is greater.

5.01.7 – After the completion of the thirtieth calendar year, the employee will be entitled to six weeks of earned vacation which may be taken during the thirty first calendar year. The six weeks will be paid at twelve per cent of gross wages earned during the previous calendar year in accordance with the Statement of Remuneration paid (T-4 Slips, Box 14) filed by the Company, whichever is greater.

5.02.1 – In the selection of dates, employees will be permitted to choose up to three (3) weeks of their vacation on a seniority basis in the period of June 15 to September 15 in any year. No more than twenty (20) per cent of the permanent working force, in any department, is to be absent on vacation at any time (excluding employees on

weekly indemnity — long term disability and Workers' Compensation). It is understood that vacation scheduling will not interfere with the orderly operation of the plant. Vacation dates shall be selected and marked on the vacation sheet before April 15 of each year. Any employee failing to do so shall use only vacant days. The Company agrees to give the vacation pay to which the employee is entitled one (1) week preceding such vacation, providing adequate notification of two (2) weeks is supplied.

5.02.2 — When operating conditions permit, vacation restrictions may be amended to allow extra personnel to take vacations at the same time.

5.02.3 — Employees vacation period will begin on the first day of their regular work week and will end at the starting time of their first regular scheduled shift after their vacation. Consideration will be given on starting on other than the first day of their regular work week when warranted, in any case vacations must be taken in units of a work week. When a stat holiday falls during an employees vacation, then their vacation will end on the beginning of their first shift, after the day they observed as the statutory holiday. If an employee should observe the statutory holiday before his scheduled vacation starts, then his vacation ends on the starting time of his first regular scheduled shift after his vacation is finished.

5.04 — No employee shall be entitled to vacation with pay under the provisions of Article 5 unless he has actually worked as an employee of the Company for a minimum of 500 hours during the calendar year period January 1-December 31.

An employee who is not entitled to full vacation pay under this clause shall receive the applicable percentage of his gross earnings based on seniority.



**ARTICLE 6 – WAGE RATES**

**6.01 –** The wage scales covered by this Agreement are attached hereto as Article 16.01 and become effective October 1, 1991, and will remain in effect until September 30, 1994.

**6.02 –** If a new job is created or an existing job is materially changed, an applicable rate shall be negotiated between the parties and in the event of failure to reach an agreement, will be subject to arbitration procedure as contained in this Agreement. It is understood between the parties that prior to reaching agreement on this wage rate the Company may fill the position but that the wage rate shall be retroactive to the date on which the position was filled.

**6.03 –** The rate of pay of any employee who is temporarily required to fill the place of an employee receiving a lower rate shall not, for that reason, be reduced, and any employee who is required to perform work for which a higher rate than that of their classification is paid, shall receive such higher rate of pay. Any employee required to work on two (2) or more jobs having different rates shall be paid the rate of the highest rated job for his entire work day.

**6.04 –** No employee shall be entitled to hold more than one relief position in addition to his regular classification.

**6.05 - Shift Premium**

	Oct. 1, 1991	Oct. 1, 1992	Oct. 1, 1993
Afternoons 16:00-24:00	\$0.45	\$0.50	\$0.50
Midnights 00:00-08:00	\$0.60	\$0.65	\$0.65

To receive the shift premium, employees must be assigned to shift work.

## ARTICLE 7 – SENIORITY OF SERVICE

7.01 – The Company accepts the principle of seniority of service. This principle shall be applied as follows:

Seniority of service shall date from the Employee's most recent starting date with the company in local lodge D 366.

7.02.1 – The Company will establish a seniority list to be revised quarterly indicating the status of all present employees in order of the date of their employment and classification with the Company. Fifteen (15) copies of the seniority list to be given to the union.

7.02.2 – New employees shall not be placed upon the Seniority list until they have worked and earned pay for Sixty Days.

7.02.3 – The Company agrees to notify the Plant Union Chairman in writing the name, date and position of new employees hired, also termination dates and names.

7.02.4 – It is agreed that students may be hired to work within the bargaining unit for up to four (4) calendar months. Students will only hold classified jobs after regular workers have been asked and refused, except Packer Loaders. Students shall be required to pay an amount equivalent to Union Dues, but shall not be required to pay the initiation fee. Such students shall receive the applicable hourly rate. The term "student" shall apply only to persons hired who have completed previous school year or are scheduled to return to school the following year. Should a student decide to become a permanent employee, they must advise the Company and at that time will be required to serve a probationary period, as stated in Article 7. The seniority date will be the date of hire.

7.03.1 – Job requirements outlined in job postings are not to be changed without mutual agreement.

**7.03.2** – When a new job is created or a vacancy occurs, it shall be posted by the Company for five (5) working days, excluding week-ends and Statutory Holidays, so as to give all interested employees the chance to apply in writing for such jobs. All jobs will be posted within seven (7) days from the time the vacancy occurs, except when equipment is not operating or when the job is discontinued. Vacancies will be offered to regular full time employees before being filled by a new hire.

**7.03.3** – Careful consideration will be given to applications received in relation to the following qualifications:

1. seniority
2. requirements of the job.

When factor 2 is deemed to be adequate, then seniority shall govern. This selection shall apply to all vacancies or new jobs.

**7.03.3B** – When an applicant has a “Health or Physical Fitness Problem” confirmed by a Doctor’s report, which may affect his efficiency on the posted job, his application will be discussed by a joint Union/Management Committee.

**7.03.4** – An employee going on vacation who wishes to make an application for specific vacancies that may arise during their absence, must complete application forms and leave them with the Plant Union Chairman immediately prior to their departure.

**7.04.1** – Any employee selected will be given a fair trial not exceeding thirty (30) working days in the new classification except as outlined for those classifications in the training manual. If at any time during the trial period they have not proven themselves capable of performing the duties of the new position, they shall revert to the position they had previously held. Any employee so demoted shall have their

case discussed with the Officials of the Company by the Union Committee. If no satisfactory settlement is reached, it is understood the matter will be resolved through the Grievance Procedure.

Note: Regarding Apprentices — see Trade Appendix  
Regarding Production Training Manual — see Appendix A

**7.04.1B** — Any employee who after successfully bidding for a posted job, who voluntarily withdraws from the new job position, will be disqualified from bidding for a one year period.

Day shift employees who successfully bid for and are awarded a job posting in a classification “6” or higher on shift, will be required to remain on shift for a minimum period of 12 months.

Shift employees may bid for a higher classification job at anytime.

Shift employees who bid and are awarded a lower classification job will be required to remain in such classification for 12 months, except where the union and the company mutually agree otherwise.

**7.04.2** — Should the selected applicant decide to withdraw from the new job within the trial period, or should he fail to perform the new duties during the trial period, this withdrawal or failure will cause a vacancy and the next qualified applicant on the job posting list will get the job and the employee shall revert to his former position.

**7.04.3** — During the trial period the Supervisor shall make a progress report at the end of ten (10) days, twenty (20) days, and thirty (30) days except as outlined for those classifications in the training manual. The report will be in triplicate, one copy to the employee, one to the Plant

Union Chairman and one copy to the Labour Relations Supervisor. Upon failure to submit a report on the trainee, it will be understood that the trainee's performance has been judged satisfactory.

**7.05** – When a posted position has been filled, the Company will post the name of the selectee within four (4) days regardless of whether they started to perform their duties at that time or at a later date.

**7.06.1** – When an employee is awarded a new job of a higher classification and for which a higher rate than that of their former classification is paid such higher rate shall become effective immediately after the employee assumes his new duties or within thirty (30) days, if he has not assumed his new duties.

**7.06.2** – When an employee is awarded a new job of a lower classification, which shall be by their own choice, and for which a lower rate than that of their former classification is paid, such lower rate shall become effective immediately after the employee is relocated to his new position.

**7.06.3** – When an employee is not going to be placed on an awarded position within thirty (30) days, the Plant Committee, with the employee, will meet with Management to find a solution.

**7.07** – An employee whose job is permanently discontinued by technological change or otherwise may apply in writing for a job in his or any other department and be considered for the job in accordance with the provisions of section 7:03.3 and 7.04.1 of this Agreement.

**7.08.1** – Seniority of service shall continue to accumulate during any lay-offs or periods of absence through proven sickness or injury. Seniority shall be determined from the date of original employment, but an employee shall lose their seniority if:

- (1) they quit voluntarily
- (2) they are dismissed for cause and not reinstated through the Grievance Procedure
- (3) they are absent for three (3) consecutive working days without permission
- (4) they do not return to work within seven (7) calendar days after receiving notification either by messenger or by registered mail to their last known address on the records of the Company
- (5) they are laid off for a period equal to their seniority at their time of layoff or for a period of two years whichever is the greater.

7.09 – The period spent by an employee in service with the Canadian or Allied Armed Forces, within the meaning of the definition in the reinstatement in the Civil Employment Act, 1942, of the Dominion of Canada, as amended, shall be considered as service within the Company for the purpose of establishing Company seniority, provided said employee **re-enters** the employ of the Company within six (6) months of discharge from the Canadian or Allied Forces.

7.10.1 – Any employee may be transferred to another department or occupational group if the employee so agrees and shall suffer no change in seniority thereby. The Company will notify the Plant Union Chairman whenever an employee is transferred. This clause pertains to transfers over one (1) week.

7.10.1B – Any employee may be transferred on a “daily basis, one (1) to forty (40) hours” to another department or occupational group and shall suffer no change in seniority thereby. The senior employee on the job classification to be moved will be asked first. Payment for transferred employees will be governed by Art. 6.03.

7.10.2 – In any four shift operation, personnel involved shall not be subject to any financial loss resulting from a change from one shift to another shift, within the four shift operation. In cases where an inter-shift transfer takes place, the Company shall compensate the personnel involved with a payment equal to the loss suffered by the employee for a period of one (1) month from the effective date of transfer.

7.10.3 – Employees requesting a job or shift change will not be entitled to compensation for any loss due to this change.

7.11.1 – The Company agrees that insofar as it shall be possible to do so, it will give notice of its intention to close down any of its operations, and will give such notice as is possible of its intention to decrease the number of personnel employed as may be from time to time essential because of business or seasonal conditions.

7.11.2 – The Company agrees that should the opening of a new plant result in lay-off of an employee at the Mississauga Plant or Ogden Point Quarry, such an employee may apply for employment at the new plant prior to its start of operation and their application shall receive preference over similar applications from persons outside this bargaining unit. Any employee transferring directly to the new plant without break of service shall carry his pension, security plan, insurance benefits, seniority and vacation credits with him.

7.12.1 – The Company reserves the right to discharge or suspend any employee for good and legitimate reason(s). The discharge of a probationary employee shall not be the subject of a grievance hereunder. The Company shall notify the Union, in writing within five days of the discharge or disciplinary time off of any employee, other than a probationary employee, stating the reason(s) for such action. Any employee who is discharged or suspended must file an appeal, in writing, within ten working days of

receiving notice of such discharge or suspension or the right to appeal is lost. A proper appeal will be taken through the Grievance Procedure at step 2. Should the employee not be prepared to accept the decision arrived at step 2, or should the Company representatives fail to give a decision within one week, then the appeal shall be immediately taken at step 3 of the Grievance Procedure.

7.12.2 — If the grievance is not adjusted within seven (7) working days, then it shall be referred within five (5) days to a single arbitrator selected by the Labour - Management Arbitration Commission, or a Board of Arbitration, which may:

- (.1) uphold the Company's action
- (.2) uphold the employee's appeal and reinstate the **grievor** to their former position without loss of wage rate or seniority and with full pay for all loss of time, or
- (.3) award such lesser penalty as the Single Arbitrator, or Board of Arbitrators, may deem fair and proper.

7.12.3 — It is further understood that the **grievor's** health and welfare and pension benefits will remain in force pending the Arbitrator(s) decision.

7.13 — The Union agrees to co-operate with the Company in regard to valid discipline and Company rules, and will make every effort to combat misdemeanours which may be considered cause for discharge and to support the Company's action in the treatment of same. Each offence shall remain on the record of the employee for a period of **eighteen (18)** months after which it shall automatically be removed and destroyed.

7.14 — Any employee who is to receive a written warning, suspension or discharge, shall be removed from their work



station and taken to a private office. The employee's steward shall be present during the interview and the foreman shall advise the employee of the offence committed. After a full investigation of the details, the Director of Personnel & Industrial Relations, Industrial Relations Supervisor or Department Manager, will advise the employee, and the Union in writing of the penalty to be imposed within six (6) working days from the day in which the offence occurred.

#### **ARTICLE 8 – LAY-OFF PROCEDURES**

**8.01 –** The Company reserves the right to lay-off employees. In the case of lay-off the least senior employee shall be laid off first. Senior employees have the privilege of lay-off if requested provided the plant operation is not affected and a junior qualified person is available. Upon recall after lay-offs, the most senior employee shall be called back first. If the Union disagrees with any action of the Company in regard to lay-offs or recall, after lay-offs, the Company will meet the Plant Committee and endeavour to reach an agreement according to Article 9 of this agreement.

**8.02.1 –** When an employee will be temporarily laid off for fourteen (14) calendar days or more, and who has the required seniority, may apply in writing for a job in their or any other **department**, and if they can satisfactorily perform the job without a training period, they shall replace the regularly classified employee, will be paid at the wage rate of the new job.

**8.02.2 –** On total recall an employee exercising his rights under **8.02.1** shall revert to their former position.

**8.03 –** Lay-offs are to be done in accordance with the **Ontario** Employment Standards Act.

**8.04 –** The Company agrees to grant top seniority in case of lay-offs, to the following Union Representatives but in accordance with the provisions of Article **8.02.1**:

President  
Plant Union Chairman

**ARTICLE 9 – PLANT COMMITTEE  
GRIEVANCE PROCEDURE AND ARBITRATION**

9.01.1 – The Company agrees to recognize 10 elected representatives of Lodge D 366 as the in-house Union Committee. They are as follows – 1) Plant Union Chairman and one Steward from each of the following areas: Packhouse, In-Plant Transport, Maintenance including Stores, Yard Crew, Quarry, and one for each shift for a total of nine.

The Company also recognizes each employees right to hold office in his local and will allow sufficient leave (without pay) for that job to be carried out.

9.01.2 – For the purpose of solving plant controversies or other problems other than grievances, a plant committee of four (4) representatives of management and four (4) representatives of the Union (Plant Union Chairman and three (3) stewards) shall meet as required or at the request of either party. Meetings shall take place during working hours with no loss of pay for Union representatives in attendance.

9.01.3 – The Plant Union Chairman shall be allowed a reasonable amount of time (without loss of pay) for the purpose of servicing contract.

9.01.4 – The Union agrees to furnish the Company with the names of the Plant Union Chairman and Stewards who are authorized to carry out the provisions of this section.

9.01.5 – The Plant Union Chairman to be on days. The employee will be paid the applicable rate for job he or she is performing.

9.01.6 – If additional departments or shifts are created, the parties agree to negotiate further representation.

**9.02** – For the purpose of adjusting grievances, the Company shall **recognize** a grievance committee to process grievances as outlined in section **9.05**. Meetings of the grievance committee shall take place during working hours with no loss of pay for the representatives of the Union attending the meeting(s). In each case, the Plant Union Chairman and/or Steward shall be permitted to use a reasonable amount of time to investigate the grievance. In each case, the Plant Union Chairman and/or Steward shall give notice to their immediate supervisor of the need of those investigations.

**9.03.1** – The Company and the Union agree that they will endeavour to settle grievances as promptly as possible. All grievances shall be submitted in writing on forms provided for this purpose by the Company.

**9.03.2** – The Union agrees to furnish the names of the Plant Union Chairman and Stewards who are **authorized** to carry out the provisions in Section **9.02**.

**9.04** – All decisions arrived at by agreement between the **authorized** Management of the Company and the Grievance Committee with respect to grievances shall be final and binding upon the Company, the Union and the employees.

**9.05** – A grievance must be presented within five (5) working days of the act causing the grievance but not thereafter. The working days referred to in this paragraph shall be the working days of the grieved employee.

First Stage: By an employee, his Union Steward, Supervisor, and his General Supervisor and if not settled within one (1) week after such meeting then,

Second Stage: Between Steward, Plant Union Chairman the Supervisor and the Industrial Relations Supervisor if not settled within one (1) week then,

The Plant Grievance Committee will meet as per Art. 9.02 to discuss grievances prior to the third (3) stage. The Plant Union Chairman P.U.C. will arrange these meetings with the Director of Personnel and Industrial Relations.

Third Stage: Between the District Representative the President of Lodge D 366, the Plant Union Chairman, and the Director of Personnel and Industrial Relations, Industrial Relations Supervisor, Department Manager. If not settled within seven (7) working days, then

Fourth Stage: By a single Arbitrator under section (45) of the Labour Relations Act or a Single Arbitrator selected by the Labour Management Arbitration Commission or by a Board of Arbitration, as chosen by agreement of both parties.

**9.05.1** – Grievances involving more than one employee: the Union will select one representative to attend at the grievance stages as outlined above.

**9.06** – The Board of Arbitration to be selected in the following manner:

The Union shall select one (1) arbitrator and the Company shall select one (1) arbitrator and the two so selected shall endeavour to select a mutually satisfactory third arbitrator who shall be the Chairman of the Arbitration Board. In the event the Arbitrators selected by the Union and the Company are unable to agree upon the third arbitrator, he shall be appointed by the Minister of Labour for the Province of Ontario. The decision of the Arbitration Board shall be either unanimous, or failing that, a majority, or failing a majority, the decision of the Chairman. The decision shall be final and binding on all parties involved.

**9.07** – Policy Grievance: Any difference arising directly between the Company and the Union involving the

interpretation of alleged violation of this Agreement may be submitted in writing by either party at the third step of the grievance procedure.

**9.08** — Grievance in writing must be accepted at steps one and two. Failure to do so will cause the Grievance to proceed to step two and step four respectively.

**9.09** — The Arbitration Board shall not **alter**, add to, subtract from, modify or amend any part of this Agreement.

**9.10** — The expense and compensation of the arbitrators selected by the Parties shall be borne by the respective **organization** selecting them. The expense and compensation, if any, of the Chairman of the Arbitration Board shall be divided equally between the Company and the Union. Full use shall be made of the services provided by the Ministry of Labour.

#### **ARTICLE 10 — LEAVE OF ABSENCE**

**10.01** — Any request for leave of absence for a period in excess of three **(3)** consecutive working days must be made in writing to the Department Manager, who will reply in writing with a copy to the Union. The Union maintains the right to appeal the Department Managers decision to the Director of Personnel and Industrial Relations.

**10.02** — Vacations must be exhausted prior to a leave of absence being granted.

**10.03** — Employees elected or appointed as delegates of the Union, not exceeding five **(5)** in number at any one time, provided that it does not unduly interfere with operations, shall be given reasonable leave of absence without pay to enable them to perform duties of such office provided that their request for such leave of absence is transmitted to the Management of the Company at least seven days before the first day of the period for which the leave of absence is requested.

**10.04** — Any employee elected or appointed to a full time position with the Cement, Lime, Gypsum and Allied Worker's Division of Brotherhood of Boilermakers, Iron Ship Builders, Blacksmiths, Forgers and Helpers, AFL-CIO-CFL., or any of its subordinate bodies shall be granted an indefinite leave of absence providing ten (10) days notice is given the Company prior to beginning of such leave. During such leave, seniority shall not continue for purposes of pension, insurance benefits shall be suspended after thirty (30) days of such leave and will again be in effect the first day of returning to work with the Company. Upon returning to work, such employee will be reinstated in their former job, providing it is still in existence. If not, they shall be eligible to apply for any job within the bargaining unit by means of existing procedure or by bumping.

**10.05** — Upon written application to the Director of Personnel and Industrial Relations, an employee with at least one (1) year seniority may for good and sufficient cause be granted a leave of absence without pay for a limited period not to exceed sixty (60) days provided that no disruption to operations will occur. Such leave of absence may be extended, upon request to the Company.

**10.06** — The Company will notify the Plant Union Chairman of any leave of absence granted, or refused. In cases of refusal, reasons to be specified on Leave of Absence Application. Any employee on leave of absence who engages in other employment or fails to report for work on the expiration of their leave shall be deemed a voluntary quit.

**10.07** — A leave of absence obtained under false pretenses shall be cause for discharge or disciplinary action.

**10.08** — The Company agrees to grant immediate leave of absence(s) to any employee who holds the position of President or Vice-President of the Local Union, to attend any official business pertaining to all Units comprising

Lodge D 366, providing that a replacement can be found. Every effort will be made, by both parties to find a replacement.

**10.09** -- When a union employee is offered a salaried position with the company, he/she will be allowed to take a leave of absence from the union for 3 months without loss of seniority. If the employee wishes to return to the bargaining unit he/she will be placed in any available position open at that time.

#### **ARTICLE 11 – JURY DUTY AND BEREAVEMENT**

**11.01** -- An employee who is called or subpoenaed for Jury or Witness Duty shall be excused from work for any day on which they report for such Jury or Witness Duty, and shall receive for **each such** day on which they otherwise would have worked, the difference between eight times their regular hourly rate and the payment they receive for Jury or Witness Duty. Should an employee be required to work the midnight shift the day going on Jury Duty, they shall have that shift off with full pay and be paid as above. Employees subpoenaed for Jury or Witness Duty to immediately notify the Company.

**11.02.1** -- Should an employee's father, mother, brother, sister, spouse, child, mother-in-law, father-in-law, **brother-in-law**, or sister-in-law die, an employee, on request, will be excused with pay, for three **(3)** days, a maximum of six **(6)** days in the case of multiple deaths on the same date, (or for such fewer days as the employee may be absent) immediately following the date of death(s).

**11.02.2** -- Should an employee's grandfather, grandmother, or grandchild die, an employee, on request will be excused with pay, for a maximum of two **(2)** days, a **maximum** of four **(4)** days in the case of multiple deaths on the same date, (or for such fewer days as the employee may be absent) immediately following the date of death(s).

11.02.3 – In all cases, application for bereavement entitlement, including proof of death, must be made to and approved by the Director of Personnel and Industrial Relations. Upon approval employees will be paid for Bereavement leave [excused day(s)] in the next pay period. The employee must submit proof to the company within four (4) weeks of the death. If the employee fails to provide proof of death the company maintains the right to deduct any monies necessary from the employees pay.

11.02.4 – The above benefits shall not be implemented if the bereavement period falls during sick leave, accident leave, lay-off, leave of absence, weekend or vacation period.

#### **ARTICLE 12 – STRIKES AND LOCKOUTS**

12.01 – During the term of this Agreement and in consideration of the relations established by it, it is agreed that neither Union nor its representatives nor any member of it shall cause, sanction, **authorize** or take part in any strike, either partial or complete, interfering with or causing interruption or stoppage of production, nor shall the Company cause or practice any lockout.

#### **ARTICLE 13 – COMPULSORY CHECK OFF**

13.01.1 – The Company shall deduct from the pay of all employees covered by this Agreement, on the first pay day of each calendar month, a fixed sum of money equivalent to the monthly Union dues and shall remit the same prior to the last day of said month in which the deduction is made, by cheque to the Financial Secretary, Cement, Lime, Gypsum and Allied Worker's Division of Brotherhood of Boilermakers, Iron Ship Builders, Blacksmiths, Forgers and Helpers, AFL-CIO-CFL, and marked "for deposit only."

13.01.2 – The said sum shall be accepted by the Union as the regular monthly Union dues for those employees who



are members of the Union and the sum so deducted from non-Union employees shall be treated as their contribution towards the expenses of maintaining the Union.

**13.02** — Upon completing the probationary period, the employee shall have deducted from his pay, an amount to be remitted to the Financial Secretary Treasurer Cement, Lime, Gypsum and Allied Workers' Division of Brotherhood of Boilermakers, Iron Ship Builders, Blacksmiths, Forgers and Helpers, **AFL-CIO-CFL**, in the form of a cheque and marked "for deposit only." Total amount of Union Dues (not initiation fees) paid by an employee shall be included in the **T-4** Slip.

**13.03.1** — All employees who are members of the Union in good standing as of the effective date of this Agreement, shall continue their membership as a condition of employment.

**13.03.2** — All employees hired after the effective date of this Agreement shall become and remain members in good standing of the Union, as a condition of employment, as soon as their probationary period is over.

**13.04** — The Company agrees to furnish bulletin boards of its own selection to be located in conspicuous locations in the operations, for exclusive use of officials of the Union for posting of notices to bear the seal of the Union and signature of its proper officials.

Bulletin Boards — Mechanical Maintenance (Electrical Maintenance — Stores) Yard — Packing Plant — Production — In Plant Transport — Old Guard House — New Change Room Lobby.

#### **ARTICLE 14 — CONTRACT WORK**

**14.01** — The Company reserves the right to contract out any work of a repair, construction, quarry and transportation nature.

**14.01.2** – The company reserves the right to contract out maintenance or production work customarily performed by its own employees provided. a) that the Company does not have the facilities, equipment and or trained personnel available to properly perform the work as required.

**b)** that any employees on lay-off, trained and capable of performing the work as required are recalled as per article 8.01.

**14.02.1** – The Company agrees to notify the Union in advance and to meet with the Union upon the request of the Union for explanation of the reasons causing the Company to decide to contract any production and maintenance work.

**14.02.1B** – If contracting out of work is required on an emergency basis the company will notify the Plant Union Chairman or his designate.

**14.02.1C** – All contractors will be required to follow St. Lawrence Cement rules and the Occupational Health and Safety Act.

**14.02.2** – If policy grievance is filed by the Plant Union Chairman for the second time, an equivalent to four (4) hours shall be paid at applicable wage rate to Local Charitable Organization.

**14.03.1** – No persons outside the bargaining unit shall perform work that is customarily performed by employees in the bargaining unit, except as outlined in the following:

(.1) to instruct, inspect, experiment

(.2) in the case of an emergency, to avoid injury or loss of life or damage to property, material or machinery.

**14.03.2** – For any violation of Article 14.03, the Company shall be required to pay a minimum of four (4) hours pay at the applicable overtime rate to the most senior employee(s) who is qualified to perform the type of work involved and who files a grievance that is found to be valid. Any settlement under this Section shall not exceed the number of contracted employees not total hours worked.

**ARTICLE 15 – GROUP LIFE INSURANCE,  
SICKNESS AND DISABILITY PLAN**

15.01 – For the life of this Agreement the Company will continue the Group Life Insurance, Sickness and A.D. and D. Plans at the following scales:

	Oct. 1/91	Oct. 1/92	Oct. 1/93
Life Insurance	\$36,000	\$37,000	\$38,000
A.D. and D.	\$36,000	\$37,000	\$38,000

Employees retiring at age 65 with minimum 12 years service \$3,000 Life Insurance.

15.02.1 – Weekly Indemnity Payment is 24 times hourly rate. Weekly Indemnity will be paid on a five schedule work day basis. Weekly Indemnity is payable on the first day of accident and the fourth day of sickness for a total of twenty-six (26) weeks.

LTD. A payment of \$1,000 max per month will be paid to employees on LTD. The term of this payment will vary depending on length of service up to age 65.

0-10 years	10 year maximum
over 10 years	equal to length of service

This LTD is exclusive of all other payments.

15.02.2 – The Company pays for second and third scheduled work day at one fifth (1/5) weekly indemnity rate for sickness provided the employee qualifies for Canada Life Benefits.

15.03 – No deductible on the Group Insurance Plan,  
Dental Plan, Canada Life.  
Routine treatments, no maximum.  
Major treatments, maximum \$1,000 per year per person.

Co-Insurance: **80%** for routine and **50%** for major.  
Deductible: **\$10** (2 per family).

Ryder 4 Orthodontic Care

Orthodontic expenses **\$1,500.00** lifetime maximum (eligible dependent children only) Co-share of all premium cost **50%/50%** and Co-share premium cost increases **50%/50%**, resulting from plan experience. (Orthodontic plan only.) Subject to insurance company paying **50%** of each individual claim up to the lifetime maximum.

15.04.1 – Dental Plan Update

ODA	YEAR
1991	1992
1992	1993
1993	1994

15.04.2 – New employees will not be covered for dental plan until they have completed one year of seniority.

15.05 – If Government Legislation or Regulation is enacted that alters or amends the premium payment method of any of the Company paid benefits, the Company shall stop all payments under the old system, using the funds thereby to make payment under the new method. The Company is to receive the benefit of any reduction in costs generated by the change.

15.06 – Vision Care

Effective the first **(1st)** month after ratification a family vision care program providing **\$120.00** of coverage per family member every two **(2)** years, and subject to the conditions as described in the Health Protection Benefits Booklet as established.

15.07 – Benefits in this Article, apply only to employees who have completed their probationary period.

15.08 – The Company to provide the Union with five (5) copies of the Master Policy of the plans contained in the article.

15.09 – The Company will continue to provide Drug Plan coverage to employees who retire early and are 60 years of age with a minimum of 20 years of service.

**ARTICLE 16 – CLASSIFICATIONS,  
WAGES AND C.O.L.A.**

16.01.1 – The following rate and classification shall apply for the duration of this Agreement,

<b>CLASS</b>		<b>Effective</b>	<b>Effective</b>	<b>Effective</b>
<b>No.</b>	<b>Classificaitons</b>	<b>Oct. 1/91</b>	<b>Oct. 1/92</b>	<b>Oct. 1/93</b>
	Student rate	10.00		
	Probationary Employee	\$13.27	\$13.27	\$13.27
1	Labourer	16.08	16.64	17.19
2	<b>Yardman</b>	17.17	17.77	18.36
3	Packer Loader Oiler C	17.34	17.95	18.54
4	<b>Yardman</b> Senior Crusher Convey or Att Mobile Vacuum Laboratory Helper B	17.51	18.12	18.72
5	Crusher Attendant	17.64	18.26	18.86
6	Dust Collector Man 1st Year Boat Loader Quarry Boat Loader/Unloader Bulk Loader Bulk Loader <b>Scaleman</b> Bulk Loader Switchman Shift Helper Oiler B 1st Year <b>Storeman</b>	17.81	18.43	19.04

7	Locomotive Operator	\$17.94	\$18.57	\$19.18
8	2nd Year Dust Collector Man Gardener A. Laboratory Helper A <b>Storeman</b> Truck Diver – Plant Primary Crusher Operator – Gyro.	18.11	18.74	19.36
9	Packhouse Man Senior. Crane Operator	18.27	18.91	19.53
10	Coal System Attendant Loader Operator Machine Attendant Jr. Kiln Helper Dust Collector Man <b>3rd Year</b> Senior Crane Operator	18.41	19.05	19.68
11	Machine Attendant Sr. Oiler A. Sr. Dust Collector Man <b>(1 only)</b> Driller Blaster	18.72	19.38	20.02
12	Shipper Receiver Tower Operator	18.87	19.53	20.17
13	Loader Operator 15 Yard & Over Shovel Operator Senior Oiler (Note 1 only)	19.17	19.85	20.51
14	Burner Material Tester Quarry <b>Demag</b> Shovel (when operating)	19.94	20.64	21.32

15 Console Operator B up to 400 hours of Solo Operation	\$20.11	\$20.81	\$21.50
16 Console Operator	20.71	21.43	22.14
<b>Trade Appendix</b>	<b>Effective</b>	<b>Effective</b>	<b>Effective</b>
	<b>Oct. 1/91</b>	<b>Oct. 1/92</b>	<b>Oct. 1/93</b>
"A" Journeyman	19.94	20.64	21.32
"B" Senior Journeyman	20.32	21.11	21.89
Trade Apprentices			
"C" 1st year	17.64	18.26	18.86
"D" 2nd year	17.94	18.57	19.18
"E" 3rd year	18.27	18.91	19.53
"F" 4th year	18.57	19.22	19.85

Trades Premiums: Certified Millwrights, Electricians, Motor Mechanics, and Carpenters (Journeyman 1st Class) holding a Provincial Trades ticket **recognized** in the Province of Ontario and classified under this agreement shall receive a premium of **60** cents Oct. 1:91, increasing to **70** cents Oct. 1:92 and increasing to **80** cents Oct. 1:93. This payment will be calculated on actual hours worked,

Maintenance trade scheme under Department of Labour: Leading duties deleted from Senior Journeyman requirements. Certified welder, and kiln liner to be included in Senior Journeyman list.

Tool Allowance Payments Electricians	\$ 50.00
Fourth Year Apprentice Electricians	50.00
Third Year Apprentice Electricians	50.00
Second Year Apprentice Electricians	35.00
First Year Apprentice Electricians	35.00

Millwright Maintenance	\$100.00
Fourth Year Apprentice Millwright	80.00
Third Year Apprentice Millwright	60.00
Second Year Apprentice Millwright	45.00
First Year Apprentice Millwright	25.00
Motor Mechanic	175.00
Fourth Year Apprentice Motor Mechanic	125.00
Third Year Apprentice Motor Mechanic	90.00
Second Year Apprentice Motor Mechanic	70.00
First Year Apprentice Motor Mechanic	40.00
Motor Mechanic Helper	15.00
Building Repair Man	100.00
Norblo Man	25.00

**ST. LAWRENCE CEMENT, INC. AND MINISTRY OF  
COLLEGES AND UNIVERSITIES**

**APPRENTICESHIP PROGRAM**

Requirements: Minimum of Grade 10 — proof to be supplied (English, Mathematics and Science required subjects) “These requirements will follow the Government guidelines.

Three periods of Ministry of Colleges and Universities Trade Course:

First Period — 8 weeks (heavy duty mechanic 12 weeks)

Second Period — 7 weeks

Third Period — 7 weeks.

1. Millwright Apprentice — 3 Periods of 1 day per week for 30 weeks.
2. Hours missed by Apprentices during school term will be deducted from their pay on company receiving notification from the Apprenticeship Branch of their absence.



3. Change of pay rate from Fourth (4) year apprentice to Journeyman will be from completion of apprenticeship hours and successful completion of Trade certificate examination.
4. On completion of Apprenticeship and school hours, apprentice must take his certificate of qualification **examintion** within three (3) months. Failure to take this examination, apprentice will be relocated to the yard crew and apprenticeship will be terminated.
5. If apprentice fails his first trade certificate examination, he will be allowed to rewrite the examination within ninety (90) days following the first examination.
6. If apprentice fails the second (2) examination the apprenticeship will be terminated with the employee being assigned to the yard crew department, class two (2).
7. If the employee takes a third (3) examination and successfully attains his trade certificate (this being at no cost to the company) he will be given consideration for the first opening in his trade.

Ministry of Colleges and Universities registration fee must be paid by applicant.

Weekly wages of Apprentice will be made up by the Company (difference between Ministry of Colleges and Universities pay and allowance and weekly salary S.L.C.) minus \$10.00 per week.

The \$10.00 per week will be paid back on successful completion of each Ministry of Colleges and Universities Instruction Course.

Each Apprentice is responsible for providing proof of attendance at school to the Company.

Apprentice will attend approved trade related night school courses (four courses to be taken as laid down in Apprenticeship training schedule).

Company will pay **75%** of night school course fee.

As per Trades Appendix           **0-2,000** hours (first year)

As per Trades Appendix   **2,000-4,000** hours (second year)

As per Trades Appendix       **4,000-6,000** hours (third year)

As per Trades Appendix       **6,000-8,000** hours (fourth year)

Hours calculated on regular working hours and school attendance.

Each Apprentice to be reviewed at the end of each trade year, by Plant Manager and Maintenance Manager, Plant Union Chairman and Maintenance Steward.

Assessment of each Apprentice will be taken from school and supervisor's progress reports.

If assessment is positive, Apprentice will move up two classes. If assessment is negative Apprenticeship will be discontinued – Apprentice is then governed by item **#3**.

Dates of entering Mechanical Electrical and Maintenance Department and acceptance by Ministry of Colleges and Universities will be used.

Termination of Apprenticeship may be **made at** any time by the Company, Ministry of Colleges and Universities or Apprentice.

For Journeyman Status (following Apprenticeship):

- 1) Successful completion of Ontario Government Approved Training Scheme.

- 2) Successful completion of approved **trade related** night school courses.
- 3) Any person failing to meet necessary Government or Company requirement during training will be relocated to Yard Crew at Class **#2**.
- 4) The Company will have the right to transfer or terminate employment of any Apprentice for causes such as:
  - (a) inability to learn
  - (b) improper conduct
  - (c) unreliability
  - (d) irregular work attendance

Note

Probationary period not to exceed **50** working days. If performance is not acceptable Apprenticeship may be terminated at any time during probationary period.

When the Company determines that a vacancy exists for an Apprenticeship it shall be posted by the Company for five working days so as to give all interested employees the chance to apply in writing for such jobs.

Careful consideration will be given to applications received in relation to the following qualifications:

- 1) Seniority
- 2) Experience — (education, credited trade courses)
- 3) Ability

16.02.1 — Employees assigned to assist with piking while kiln is operating will be increased two classifications to a maximum of class **#9**.

16.02.2 — Class **#10** Loader Operator will operate: Loaders, Bull Dozer, Grader and Backhoe. It is understood that the Backhoe may be operated by properly trained yard crew personnel, when In-Plant Transport Loader Operators are not available.

16.03.1 – Maintenance Journeyman move to Senior Journeyman after two years plant experience.

16.03.2 – The following employees will retain the rights to the jobs indicated below during their regularly scheduled hours of work and until they either bid out or retire from said jobs or the job is permanently discontinued

M. Pederson	Relief Material Tester
S. Pratt	Relief Burner

16.04.1 – Duties of Yardman Senior; normal yard duties, drive yard dust truck, drive pick-up truck, build scaffolding, clean rectifiers, service plant filters, drive fork lift, drive mobile sweeper, operate vacuum cleaner-Hy-Vac, and mobile vacuum, operate ball sorting machine, gardener's helper and painting.

Qualifications: must have completed one (1) year as Yardman – Class #2.

16.04.2 – Any yard crew employee who has been trained for more than one (1) classification for the purpose of "relief", in case of vacation, illness, etc., will receive one (1) class higher than their normal rate, except when relieving a regularly classified operator, relief oiler, laboratory, stores, nor-blo. Whenever relief of a regularly classified operator occurs, the higher rate shall apply, as per Article 6.

16.04.3 –

Senior Bricklayers (3)	as per Trade Appendix Sr Jn
Bricklayers (3)	as per Trade Appendix Sr Jn
Bricklayers Helpers (6)	Class 10

When crew falls below required number of members, Committee will fill the vacancies by posting (only Bricklayers Helpers).

16.04.4 -- Two classes higher paid to **Yardman** when working in the Kiln to a maximum of Class 8.

16.04.5 -- Rates for sections 16.04.3 and .4 are effective on commencement of **re-bricking** or refractory in the rotary section of the kiln.

16.04.6 -- Yard crew men to be paid 2 classes higher when sand blasting.

16.04.7 -- After one year of employment Class #1 labourer to move to Class #2 **yardman**.

16.04.8 -- **Yardman** to go from Class #2 to Class #4 after two years.

16.05.1 -- During the first contract year of this Agreement, the C.O.L.A. provision will only be activated by a 10% rise in the C.P.I., September 1991 being the base month. Any monies generated above the new triggered base will be calculated and paid for quarterly, the last payment if any to be in July, 1992.

Similarly, in the second year of this Agreement, the C.O.L.A., provision will only be activated by a 10% rise in the C.P.I., July 1992 being the base month. Any monies generated above the new triggered base will be calculated and paid quarterly, the last **payment** if any to be in July 1993.

Similarly, in the third year of this Agreement, the C.O.L.A. provision will only be activated by a 10% rise in the C.P.I., July 1993 being the base month. Any monies generated above the new triggered base will be calculated and paid quarterly, the last payment if any to be in July 1994.

16.05.2 -- C.O.L.A. increase will be calculated using the consumer price index as published by Statistics Canada (1986 = 100).

- (.1) C.O.L.A. increases will be calculated using the consumer price index as published by Statistics Canada (1986 = 100).
- (.2) A one (1) cent per hour increase will be made to each classification for every .275 increase in the C.P.I. over the previous quarter.
- (.3) The amount of any C.O.L.A. benefits in effect at any time shall be included in computing overtime pay, holiday pay, call-in pay, vacation pay, jury duty pay and bereavement pay.
- (.4) Increases will take effect the first pay period after the publication of the months' C.P.I.

**16.06.1** – Each crew of 3 men will receive a bag bonus of \$0.75/100 bags per man for every 100 bags over 3,500 bags per crew. The Company will endeavour to have only the minimum number of crews bagging so bonus can be maximized. When all available men are not required for bagging, available men will be rotated on a weekly basis.

**16.06.2** – Truck Driver (Class 8) assigned to Packhouse Department and Senior Man (Class 9) will receive average bonus of highest two crews receiving bonus.

**16.06.3** – Senior man will be able to fill in for any job in the Packhouse.

**16.06.4** – If only one crew is bagging – Shunt Driver and Senior Man will receive bonus of that crew.

**16.06.5** – Same bonus applies during overtime.

**16.06.6** – If a Packer Loader arrives late, the employee who replaced him, will have the choice whether he continues bagging or performs other duties assigned.

16.06.7 – In case of reduction in the number of crews, the employee will receive the rate of the classification to which they are assigned.

16.06.8 – Regular Packhouse employees, who are qualified, will be given the opportunity of performing available work, when not working at their regular assignments.

#### ARTICLE 17 – PENSION PLAN

17.01 – All employees governed by this Agreement are eligible to receive benefits under the Company Pension Plan, subject to the terms and provisions of the Plan as amended and upgraded as follows:

- (.1) to 1982 earnings in 1988, which means above earnings times number of years in plan – previous plan was total year by year earnings. Company guarantees that employees retiring during the life of this Agreement will receive the updated base year that is negotiated during next contract negotiations. The maximum pension received shall not exceed the pension calculated on the best five (5) consecutive years.
- (.2) vesting after five (5) years, no age requirement.
- (.3) interest is 7 per cent.
- (.4) widows will receive half pension for a lifetime. The employee must be married for three (3) years before retirement for the widow to qualify for the above mentioned pension.

New employees upon reaching the age of 30 must join the Pension Plan. The Plant Committee may appoint a member who may meet with Management of the Company to discuss the Pension Plan. Plant Union Chairman to inform all new employees of their rights under the Pension Plan.

17.02 – The Company shall provide the Local Union with two (2) copies of the official plan text.

**17.03 – Pre-Retirement Plan**

Minimum twelve (12) years service when person reaches age of sixty-four (64) and nine (9) months. They will work a four (4) day week and receive pay for five (5) days during the last three (3) months prior to their retirement date.

If an extension of employment is granted – benefits deferred to three (3) months prior to retirement.

**ARTICLE 18 – SECURITY PLAN**

**18.01 –**

Oct. 1, 1991	Oct. 1, 1992	Oct. 1, 1993
\$100.00	\$125.00	\$125.00

- a) Monies to be placed in individual interest bearing accounts.
- b) Withdrawal of accumulated funds on death, retirement or cessation of employment, the only exception being an employee when on lay-off may draw up to \$80.00 per week while laid of.
- c) Funding level to be as stated above regardless of hours worked in the year.
- d) Eligibility is limited to employees with six months service or more.
- e) Plan will be administered by the Plant Union Chairman and Company Plant Controller.

**ARTICLE 19 – HEALTH AND SAFETY**

19.01 – Injuries of any nature whatsoever shall be reported by the injured employee to their Foreman.



**19.02** — The Company will continue to furnish in accordance with the provisions of the Workers Compensation Act, first aid and medical services to its employees in all cases of accidental injury occurring in and arising out of their employment. A complete medical examination of any employee including x-ray (at the Company's expense) may be made annually or at any time at the discretion of the Company. Copies of reports of such examination and reports of treatment shall be kept on file by the Company, and shall be at all times available to the employee's physician for reference.

**19.03** — The Company will, according to its established practice, continue to install such safety devices for the protection of lives and health of its employees as shall be mutually agreed upon by its representatives and the Plant Safety Committee. It is understood that it is compulsory for all employees to wear hard hats, safety boots, safety glasses, and hearing protection at all times when on the job. The hard hats will be supplied by the Company. Safety glasses on prescription and plain are supplied free of charge when necessary, provided employee takes care of glasses. Employees using other than the designated optometrist shall be reimbursed to a maximum of **\$45** every two **(2)** years.

**19.04** — Disciplinary action related to safety infraction(s) shall be dealt with by the Plant Safety Committee. Safety rules shall apply also to all outside persons entering the plant premises.

**19.05.1** — The Company agrees to notify the Safety Committee prior to the receiving of any waste solvents. It is understood that safety rules shall be in accordance with the provisions established from time to time by the Ministry of the Environment or any other agency established to control the handling of waste solvents.

**19.06.1** — All clothing, tools and equipment shall be **maintained** in a safe and efficient working order, and the

regulations and safety codes adopted by the Province of Ontario in the interest of protecting safety and health of industrial employees as they affect the industry shall be strictly observed by both parties.

**19.06.2** – All tools and equipment belonging to the Company will be subject to a safety check once monthly by a maintenance supervisor and the Safety Committee of the Union.

**19.07** – The Joint Plant Safety and Health Committee will consist of an equal number of representatives from the Company and the Union. The duties of the Committee consist of making recommendations for the improvement of safety and investigation of all accidents. The Committee will work toward the elimination of safety hazards. The Committee will meet monthly and discuss safety programs and accident reports including the inspection of work sites if necessary. Members of the Safety Committee to do a safety inspection of the entire plant quarterly – one (1) section at a time. Written report to be completed on same. Plant Union Chairman to be a member of Safety Committee.

**19.08** – Employee rights regarding safety are protected by the Occupational Health and Safety Act.

**19.09.1** – The Company agrees that no employee shall be permitted to work in excess of sixteen (16) consecutive hours except in cases of extreme emergency.

**19.09.2** – For any violation of this section, the following penalties apply:

- (.1) The Company shall be required to pay four (4) times the hourly rate of the employee, or employees involved for each hour in excess of sixteen (16) consecutive hours worked. To be paid to Lodge D 366 for distribution.

(.2) The employee, or employees working in excess of sixteen (16) consecutive hours shall have forfeited the right of overtime premium rate, regardless of the provisions of Article 3 for all hours worked in excess of sixteen (16) consecutive hours.

19.09.3 -- For the purpose of sections 19.09.2 (.1 and .2) a period of rest of not less than eight (8) consecutive hours, the minimum limit of time required to break the consecutiveness of sixteen (16) hours.

#### ARTICLE 20 -- CLOTHING

20.02.1 -- Packer Loaders and Tower Operators to receive a maximum of two standard pair of safety boots, at no cost, in any continuous twelve month period. All other employees will receive one standard pair of safety boots, at no cost, per calendar year.

20.02.2 -- New employees will supply and pay for their "safety boots" during the first year of employment. On attainment of the employees first anniversary date, Art. 20.02.1 will apply.

20.03 -- Uniforms 50% Company paid 50% Employee paid up to a maximum of three (3) uniforms per year.

20.04 -- Parka or Windbreaker to be supplied once every two (2) years -- 50% employee paid, 50% company paid. (Employees choice.)

#### ARTICLE 21 -- DURATION

21 .01. 1 -- This Agreement shall become effective October 1, 1991 and all provisions shall continue to be in effect until September 30, 1994, and every year thereafter unless not more than sixty (60) days nor less than thirty (30) days written notice is given by either party prior to the expiration date.

2 1 .01.2 – Such written notice shall contain any changes or amendments desired and only such changes and amendments as contained in such notice shall be discussed by the conferees. It is mutually agreed that nothing in this Article shall preclude an extension of this Agreement if mutually agreed by both parties.

**ARTICLE 22 – TEMPORARY JOB DISCONTINUANCE**

**TEMPORARY BUMP:**

When an employee's job is temporarily discontinued for a period of fourteen (14) calendar days and up to one year.

- (a) When an employee is notified that his job has been discontinued for less than fourteen (14) calendar days, he shall not displace a classified employee.
- (b) When an employee is notified that his job has been discontinued over fourteen (14) calendar days and up to one (1) year, he shall be given the choice of remaining on the temporary position of bumping into classified position.
- (c) the employee applying for a classified position in their or any other department, may do so in writing, provided they can satisfactorily perform the job within a one (1) shift training period. They shall replace the regularly classified employee and will be paid the wage rate of the new job.
- (d) An employee whose job is temporarily discontinued is entitled to bump only once whether successful or not as per "C" above unless bumped by a senior employee in which case he would be eligible to a second bump.
- (e) The time an employee will have to exercise his temporary bumping rights from the time that he has been notified that his job will be discontinued will be seven (7) calendar days.

### **PERMANENT JOB DISCONTINUANCE**

When an employee's job is permanently discontinued he may immediately exercise his seniority rights and apply for a position in his or any other department. Employee's affected will be given a trial period as per article 7.04.1.

When an employee's job is discontinued for over one year he may **exercise** his seniority rights and apply for a position in his or any other department. Employees affected will be given a trial period as per article 7.04.1.

If during or at the end of the trial period, the employee cannot in the company's opinion, prove himself capable of performing the job, he shall revert to the labour classification.

**APPENDIX "A" – TRAINING**

Shift Helper Training

1.01.1 – It is the duty of a shift helper to temporarily replace classified personnel such as: machine attendants, crane operators, tower operators and kiln helpers. It is, therefore, necessary that a shift helper be trained in all those areas in order to replace "without further training" the regular operator.

1.01.2 – In order to achieve feasibility the shift helper must be trained for a definitive period of time in all those areas hereunder defined as:

AREA	TRAINING TIME
Raw Grinding	10 working days
Finish Grinding	10 working days
Overhead Crane	15 working days
Kilns 1, 2 and 3	15 working days
Preheater Tower	10 working days

1.01.3 – Since it may become necessary to train one applicant in one specific area and another applicant in another specific area "at the same time" the areas shall be interchangeable. New employees accepting this position must continue to work on processing shift work for a minimum of one year. During their probationary period the probationary rate shall apply.

1.02 – In order to regulate the training of an applicant, the following time schedule and rate of pay shall be observed for permanent employees who have completed their probationary period.

1st period	1st to 10th working day	Class 2
2nd period	11th to 20th working day	Class 3
3rd period	21st to 30th working day	Class 4
4th period	31st to 45th working day	Class 5
5th period	46th day and thereafter	Class 6

**1.03** — Should an applicant for the position of shift helper have completed training at a previous time in any of the five training areas, the training time in that area will be **50%** of that provided in Clause **1.02**. The training schedule and rates of pay will be accordingly advanced to correspond to the proper training period.

**1.04** — Should an applicant for the position of shift helper have held the position of shift helper at any time during the previous year they shall be considered fully trained and receive the shift helper rate of pay.

**1.05** — No more than thirty calendar days shall elapse between the date of the award and the actual date when the applicant assumes their training.

**1.06** — Should this section be contravened by the Company the rate of pay shall be applied as if the applicant had actually begun their training.

**2.01** — At the end of training in each area the Shift Supervisor shall compile a progress report. Copy of the report to the employee, Production Manager, to the Labour Relations Supervisor and the Plant Union Chairman.

**2.02** — Should the trainee fail, at any time, during any of the training periods, the provisions of Article **7.04.1 (A)** shall apply. Except in the case of a probationary employee where the provisions of Article **7.12.1** shall apply.

#### Console Operator Training

**1.01.1** — Training of a console operator requires a training period of six **(6)** months. It is the purpose of these provisions to regulate the training program. The program has therefore been divided into “areas” and “periods”.

**1.01.2** — These provisions outline the general training program. A detailed specific training schedule will be prepared by the Production Manager for each trainee.

**1.02** – The Production General Supervisor and the Shift Supervisor are responsible for **organizing** and **co-ordinating** the schedule outlined in the detailed training program.

**2.01** – Within 5 working days of the end of each training period, a progress report will be compiled. Individual reports will be prepared by each person who has been responsible for any phase of the training during the period. A summary report will be prepared by the Production General Supervisor. Copies of all reports will be submitted to the Production Manager, the Labour Relations Supervisor and the Plant Union Chairman.

**2.02** – Should the trainee fail at any time during the training period, the case shall be discussed by a Committee composed of the Production Manager, Labour Relations Supervisor, and the General Production Supervisor for the Company; the Plant Union Chairman, the Shift Steward and a regularly classified Console Operator for the Union.

**2.03** – In case of failure, the trainee shall revert to their original classification.



## **APPENDIX "B"**

### **MODES OF PRODUCTION OPERATION**

**1.01** – When production operation (ie equipment) is reduced, employees not required on shift, will be transferred to the utility group. Employees will maintain their regular straight time hourly rate while on days in the utility group.

**1.02** – When transfers are made, the employees affected and who have the seniority, may apply in writing for a job on "production shift" before being transferred to the utility group provided they can satisfactorily perform the job as per article \*(appendix b).

**1.03** – Transfers from production positions into the utility group will not be subject to article 7.10.1 - 7.10.2 of the collective agreement.

**1.04** – When employees in the utility group are moved or bumped to a shift position for coverage, (as per article 2.01, appendix "B") such moves will not be subject to article 3.07 shift change.

**1.05** – When employees are transferred from the utility group back to their normal shift position, they will be credited with the highest of the overtime of their department or group to which they are assigned plus one (1) hour.

**1.06** – Utility group will be on days, but other shifts may be required at times. ie: afternoons and nights.

**1.07** – Each employee transferred to the utility group, retains the right to their posted position on returning to production shift.

**1.08** – In case of plant lay-off, production employees

retain the right **under article 8.02.1** in the collective agreement.

**1.09** – Skills inventory list to be used when shift personnel are required for coverage or exercising their rights under article 1.03 appendix **“B”**.

**1.10** – Skills inventory list of shift personnel will be compiled by a joint committee of two **(2)** company and two **(2)** shift personnel selected by the union.

**1.11** – When overtime is required on production shift the regular operators including utility workers assigned to production shift on classification jobs will have the right of first refusal.

**APPENDIX B**

**UTILITY GROUP**

**2.01** — Employees in the utility group will be used as required to fill positions on shift due to, **L.O.A.**, sickness, **W.C.B.** and holidays within their job class.

**2.02** — Utility group employees will be assigned bargaining unit work by their Supervisor.

**2.03** — When shift coverage is required the most senior employee in the job class will be asked first, then equal opportunity for coverage from qualified personnel in the group.

**2.04** — If overtime is required within the utility group it will be **equalized** as per article ~~3.02~~ **3.03** of the collective agreement.

**2.05** — Hours of Work, Statutory Holiday, Overtime, Rest & Lunch Periods will be governed as per day workers in the collective agreement. When utility employees are doing shift coverage they will be governed as per shift workers in the collective agreement.

**2.06** — Vacation selection dates to be as per the present production shift agreement.

**2.07** — Any dispute arising from appendix "B" will be discussed by the company and union committee. If no satisfactory settlement is reached it is understood the matter will be resolved through the grievance procedure.

**2.08** — Unless otherwise specified, all other aspects of the collective agreement remains unchanged as per article 21.01.1.

	MARCH 1993						MARCH						MARCH/APRIL						APRIL									
	14	15	16	17	18	19	20	21	22	23	24	25	26	27	28	29	30	31	1	2	3	4	5	6	7	8	9	10
	S	M	T	W	T	F	S	S	M	T	W	T	F	S	S	M	T	W	T	F	S	S	M	T	W	T	F	S
0-8	C	C	C	C	C	D	D	D	D	D	A	A	A	A	A	B	B	B	B	B	C	C	C	C	C	D	D	D
8-16	D	D	D	A	A	A	A	A	B	B	B	B	B	C	C	C	C	C	D	D	D	D	D	A	A	A	A	A
16-24	A	B	B	B	B	B	C	C	C	C	C	D	D	D	D	D	A	A	A	A	A	B	B	B	B	B	C	C

	APRIL						APRIL						APRIL/MAY						MAY									
	11	12	13	14	15	16	17	18	19	20	21	22	23	24	25	26	27	28	29	30	1	2	3	4	5	6	7	8
	S	M	T	W	T	F	S	S	M	T	W	T	F	S	S	M	T	W	T	F	S	S	M	T	W	T	F	S
0-8	D	D	A	A	A	A	A	B	B	B	B	B	C	C	C	C	C	D	D	D	D	D	A	A	A	A	A	B
8-16	B	B	B	B	B	C	C	C	C	C	D	D	D	D	D	A	A	A	A	A	B	B	B	B	B	C	C	C
16-24	C	C	C	D	D	D	D	D	A	A	A	A	A	B	B	B	B	B	C	C	C	C	C	D	D	D	D	D

	MAY						MAY						MAY						MAY/JUNE									
	9	10	11	12	13	14	15	16	17	18	19	20	21	22	23	24	25	26	27	28	29	30	31	1	2	3	4	5
	S	M	T	W	T	F	S	S	M	T	W	T	F	S	S	M	T	W	T	F	S	S	M	T	W	T	F	S
0-8	B	B	B	B	C	C	C	C	C	D	D	D	D	D	A	A	A	A	A	B	B	B	B	B	C	C	C	C
8-16	C	C	D	D	D	D	D	A	A	A	A	A	B	B	B	B	B	C	C	C	C	C	D	D	D	D	D	A
16-24	A	A	A	A	A	B	B	B	B	B	C	C	C	C	C	D	D	D	D	A	A	A	A	A	B	B	B	

	JUNE 1993						JUNE						JUNE						JUNE/JULY									
	6	7	8	9	10	11	12	13	14	15	16	17	18	19	20	21	22	23	24	25	26	27	28	29	30	1	2	3
	S	M	T	W	T	F	S	S	M	T	W	T	F	S	S	M	T	W	T	F	S	S	M	T	W	T	F	S
0-8	C	D	D	D	D	D	A	A	A	A	A	B	B	B	B	B	C	C	C	C	C	D	D	D	D	D	A	A
8-16	A	A	A	A	B	B	B	B	B	C	C	C	C	C	D	D	D	D	D	A	A	A	A	A	B	B	B	B
16-24	B	B	C	C	C	C	C	D	D	D	D	D	A	A	A	A	A	B	B	B	B	B	C	C	C	C	C	D

	JULY						JULY						JULY						JULY									
	4	5	6	7	8	9	10	11	12	13	14	15	16	17	18	19	20	21	22	23	24	25	26	27	28	29	30	31
	S	M	T	W	T	F	S	S	M	T	W	T	F	S	S	M	T	W	T	F	S	S	M	T	W	T	F	S
0-8	A	A	A	B	B	B	B	B	C	C	C	C	C	D	D	D	D	D	A	A	A	A	A	B	B	B	B	B
8-16	B	C	C	C	C	C	D	D	D	D	D	A	A	A	A	A	B	B	B	B	B	C	C	C	C	C	D	D
16-24	D	D	D	D	A	A	A	A	A	B	B	B	B	B	C	C	C	C	C	D	D	D	D	D	A	A	A	A

	AUGUST						AUGUST						AUGUST						AUGUST									
	1	2	3	4	5	6	7	8	9	10	11	12	13	14	15	16	17	18	19	20	21	22	23	24	25	26	27	28
	S	M	T	W	T	F	S	S	M	T	W	T	F	S	S	M	T	W	T	F	S	S	M	T	W	T	F	S
0-8	C	C	C	C	C	D	D	D	D	D	A	A	A	A	A	B	B	B	B	B	C	C	C	C	C	D	D	D
8-16	D	D	D	A	A	A	A	A	B	B	B	B	B	C	C	C	C	C	D	D	D	D	D	A	A	A	A	A
16-24	A	B	B	B	B	B	C	C	C	C	C	D	D	D	D	D	A	A	A	A	A	B	B	B	B	B	C	C

	AUG/SEPT 1993						SEPTEMBER					SEPTEMBER					SEPTEMBER											
	29	30	31	1	2	3	4	5	6	7	8	9	10	11	12	13	14	15	16	17	18	19	20	21	22	23	24	25
	S	M	T	W	T	F	S	S	M	T	W	T	F	S	S	M	T	W	T	F	S	S	M	T	W	T	F	S
0-8	D	D	A	A	A	A	A	B	B	B	B	B	C	C	C	C	C	D	D	D	D	D	A	A	A	A	A	B
8-16	B	B	B	B	B	C	C	C	C	C	D	D	D	D	D	A	A	A	A	A	B	B	B	B	B	C	C	C
16-24	C	C	C	D	D	D	D	D	A	A	A	A	A	B	B	B	B	B	C	C	C	C	C	D	D	D	D	D

	SEPT/OCT						OCTOBER					OCTOBER					OCTOBER											
	26	27	28	29	30	1	2	3	4	5	6	7	8	9	10	11	12	13	14	15	16	17	18	19	20	21	22	23
	S	M	T	W	T	F	S	S	M	T	W	T	F	S	S	M	T	W	T	F	S	S	M	T	W	T	F	S
0-8	B	B	B	B	C	C	C	C	C	D	D	D	D	D	A	A	A	A	A	B	B	B	B	B	C	C	C	C
8-16	C	C	D	D	D	D	D	A	A	A	A	A	B	B	B	B	B	C	C	C	C	C	D	D	D	D	D	A
16-24	A	A	A	A	A	B	B	B	B	B	C	C	C	C	C	D	D	D	D	D	A	A	A	A	A	B	B	B

	OCTOBER						OCT/NOV					NOVEMBER					NOVEMBER											
	24	25	26	27	28	29	30	31	1	2	3	4	5	6	7	8	9	10	11	12	13	14	15	16	17	18	19	20
	S	M	T	W	T	F	S	S	M	T	W	T	F	S	S	M	T	W	T	F	S	S	M	T	W	T	F	S
0-8	C	D	D	D	D	D	A	A	A	A	A	B	B	B	B	B	C	C	C	C	C	D	D	D	D	A	A	A
8-16	A	A	A	A	B	B	B	B	B	C	C	C	C	C	D	D	D	D	A	A	A	A	A	A	B	B	B	B
16-24	B	B	C	C	C	C	C	D	D	D	D	A	A	A	A	A	B	B	B	B	B	C	C	C	C	C	C	

NOVEMBER 1993							NOV/DEC							DECEMBER							DECEMBER							
	21	22	23	24	25	26	27	28	29	30	1	2	3	4	5	6	7	8	9	10	11	12	13	14	15	16	17	18
	S	M	T	W	T	F	S	S	M	T	W	T	F	S	S	M	T	W	T	F	S	S	M	T	W	T	F	S
0-8	A	A	A	B	B	B	B	B	C	C	C	C	C	D	D	D	D	D	A	A	A	A	A	B	B	B	B	B
8-16	B	C	C	C	C	C	D	D	D	D	D	A	A	A	A	A	B	B	B	B	B	C	C	C	C	C	D	D
16-24	D	D	D	D	A	A	A	A	A	B	B	B	B	B	C	C	C	C	C	D	D	D	D	A	A	A	A	A

DECEMBER							DEC/JAN 1994							JANUARY							JANUARY									
	19	20	21	22	23	24	25	26	27	28	29	30	31	1	2	3	4	5	6	7	8	9	10	11	12	13	14	15		
	S	M	T	W	T	F	S	S	M	T	W	T	F	S	S	M	T	W	T	F	S	S	M	T	W	T	F	S		
0-8	C	C	C	C	C	D	D	D	D	D	A	A	A	A	A	B	B	B	B	B	C	C	C	C	D	D	D	D	D	
8-16	D	D	D	A	A	A	A	A	B	B	B	B	B	C	C	C	C	C	D	D	D	D	D	A	A	A	A	A	A	A
16-24	A	B	B	B	B	B	C	C	C	C	C	D	D	D	D	D	A	A	A	A	A	B	B	B	B	B	B	C	C	

JANUARY							JANUARY							JAN/FEB							FEBRUARY														
	16	17	18	19	20	21	22	23	24	25	26	27	28	29	30	31	1	2	3	4	5	6	7	8	9	10	11	12							
	S	M	T	W	T	F	S	S	M	T	W	T	F	S	S	M	T	W	T	F	S	S	M	T	W	T	F	S							
0-8	D	D	A	A	A	A	A	B	E	B	B	B	C	C	C	C	C	D	D	D	D	D	A	A	A	A	A	B	B	B	B	B	C	C	C
8-16	B	B	B	B	B	C	C	C	C	C	D	D	D	D	D	A	A	A	A	A	B	B	B	B	B	C	C	C	C	C	D	D	D	D	D
16-24	C	C	C	D	D	D	D	D	A	A	A	A	A	B	B	B	B	B	C	C	C	C	C	D	D	D	D	D	D	D	D	D	D	D	D

	FEBRUARY 1994						FEBRUARY						FEB/MAR					MARCH										
	13	14	15	16	17	18	19	20	21	22	23	24	25	26	27	28	1	2	3	4	5	6	7	8	9	10	11	12
	S	M	T	W	T	F	S	S	M	T	W	T	F	S	S	M	T	W	T	F	S	S	M	T	W	T	F	S
0-8	B	B	B	B	C	C	C	C	C	D	D	D	D	D	A	A	A	A	A	B	B	B	B	B	C	C	C	C
8-16	C	C	D	D	D	D	D	A	A	A	A	A	B	B	B	B	B	C	C	C	C	C	D	D	D	D	D	A
16-24	A	A	A	A	A	B	B	B	B	B	C	C	C	C	C	D	D	D	D	D	A	A	A	A	A	B	B	B

	MARCH						MARCH						MAR/APR					APRIL										
	13	14	15	16	17	18	19	20	21	22	23	24	25	26	27	28	29	30	31	1	2	3	4	5	6	7	8	9
	S	M	T	W	T	F	S	S	M	T	W	T	F	S	S	M	T	W	T	F	S	S	M	T	W	T	F	S
0-8	C	D	D	D	D	D	A	A	A	A	A	B	B	B	B	B	C	C	C	C	C	D	D	D	D	D	A	A
8-16	A	A	A	A	B	B	B	B	B	C	C	C	C	C	D	D	D	D	D	A	A	A	A	A	B	B	B	B
16-24	B	B	C	C	C	C	C	D	D	D	D	D	A	A	A	A	A	B	B	B	B	B	C	C	C	C	C	D

	APRIL						APRIL						APRIL					MAY										
	10	11	12	13	14	15	16	17	18	19	20	21	22	23	24	25	26	27	28	29	30	1	2	3	4	5	6	7
	S	M	T	W	T	F	S	S	M	T	W	T	F	S	S	M	T	W	T	F	S	S	M	T	W	T	F	S
0-8	A	A	A	B	B	B	B	B	C	C	C	C	C	D	D	D	D	D	A	A	A	A	A	B	B	B	B	B
8-16	B	C	C	C	C	C	D	D	D	D	A	A	A	A	A	B	B	B	B	B	C	C	C	C	C	D	D	
16-24	D	D	D	D	A	A	A	A	A	B	B	B	B	B	C	C	C	C	C	D	D	D	D	D	A	A	A	A



		MAY 1994							MAY							MAY/JUNE													
		8	9	10	11	12	13	14	15	16	17	18	19	20	21	22	23	24	25	26	27	28	29	30	31	1	2	3	4
		S	M	T	W	T	F	S	S	M	T	W	T	F	S	S	M	T	W	T	F	S	S	M	T	W	T	F	S
0-8		C	C	C	C	C	D	D	D	D	A	A	A	A	A	A	B	B	B	B	B	C	C	C	C	C	C	D	D
8-16		D	D	D	A	A	A	A	A	B	B	B	B	B	C	C	C	C	D	D	D	D	D	D	A	A	A	A	A
16-24		A	B	B	B	B	B	C	C	C	C	D	D	D	D	D	A	A	A	A	A	B	B	B	B	B	B	C	

		JUNE							JUNE							JUNE/JULY													
		5	6	7	8	9	10	11	12	13	14	15	16	17	18	19	20	21	22	23	24	25	26	27	28	29	30	1	2
		S	M	T	W	T	F	S	S	M	T	W	T	F	S	S	M	T	W	T	F	S	S	M	T	W	T	F	S
0-8		D	D	A	A	A	A	A	B	B	B	B	B	C	C	C	C	D	D	D	D	D	D	A	A	A	A	A	B
8-16		B	B	B	B	B	C	C	C	C	D	D	D	D	D	A	A	A	A	A	B	B	B	B	B	B	B	C	
16-24		C	C	C	D	D	D	D	D	A	A	A	A	A	B	B	B	B	B	B	C	C	C	C	D	D	D	D	D

		JULY							JULY							JULY													
		3	4	5	6	7	8	9	10	11	12	13	14	15	16	17	18	19	20	21	22	23	24	25	26	27	28	29	30
		S	H	T	W	T	F	S	S	M	T	W	T	F	S	S	M	T	W	T	F	S	S	M	T	W	T	F	S
0-8		B	B	B	C	C	C	C	C	C	D	D	D	D	D	A	A	A	A	A	B	B	B	B	B	C	C	C	C
8-16		C	C	D	D	D	D	D	A	A	A	A	A	B	B	B	B	C	C	C	C	C	C	D	D	D	D	A	A
16-24		A	A	A	A	A	B	B	B	B	C	C	C	C	C	D	D	D	D	D	A	A	A	A	A	A	B	B	

JUL/AUG 1994							AUGUST							AUGUST							AUGUST						
31	1	2	3	4	5	6	7	8	9	10	11	12	13	14	15	16	17	18	19	20	21	22	23	24	25	26	27
S	M	T	W	T	F	S	S	M	T	W	T	F	S	S	M	T	W	T	F	S	S	M	T	W	T	F	S
0-8	C	D	D	D	D	A	A	A	A	A	B	B	B	B	B	C	C	C	C	C	D	D	D	D	A	A	A
8-16	A	A	A	A	B	B	B	B	C	C	C	C	C	D	D	D	D	A	A	A	A	A	A	B	B	B	B
16-24	B	B	C	C	C	C	D	D	D	D	A	A	A	A	A	A	B	B	B	B	B	C	C	C	C	C	D

AUG/SEPT							SEPTEMBER							SEPTEMBER							SEPTEMBER						
28	29	30	31	1	2	3	4	5	6	7	8	9	10	11	12	13	14	15	16	17	18	19	20	21	22	23	24
S	M	T	W	T	F	S	S	M	T	W	T	F	S	S	M	T	W	T	F	S	S	M	T	W	T	F	S
0-8	A	A	A	B	B	B	B	C	C	C	C	C	D	D	D	D	D	A	A	A	A	A	B	B	B	B	B
8-16	B	C	C	C	C	D	D	D	D	D	A	A	A	A	A	B	B	B	B	B	C	C	C	C	C	D	D
16-24	D	D	D	A	A	A	A	A	B	B	B	B	B	C	C	C	C	C	D	D	D	D	A	A	A	A	A

SEPT/OCT							OCTOBER							OCTOBER							OCTOBER						
25	26	27	28	29	30	1	2	3	4	5	6	7	8	9	10	11	12	13	14	15	16	17	18	19	20	21	22
S	M	T	W	T	F	S	S	M	T	W	T	F	S	S	M	T	W	T	F	S	S	M	T	W	T	F	S
0-8	C	C	C	C	D	D	D	D	D	A	A	A	A	A	B	B	B	B	B	C	C	C	C	C	D	D	D
8-16	D	D	D	A	A	A	A	B	B	B	B	B	C	C	C	C	C	D	D	D	D	D	A	A	A	A	A
16-24	A	B	B	B	B	C	C	C	C	C	D	D	D	D	D	A	A	A	A	A	B	B	B	B	B	C	C

	OCTOBER 1994							OCT/NOV					NOVEMBER						NOVEMBER									
	23	24	25	26	27	28	29	30	31	1	2	3	4	5	6	7	8	9	10	11	12	13	14	15	16	17	18	19
	S	M	T	W	T	F	S	S	M	T	W	T	F	S	S	M	T	W	T	F	S	S	M	T	W	T	F	S
0-8	D	D	A	A	A	A	A	B	B	B	B	B	C	C	C	C	C	D	D	D	D	D	A	A	A	A	A	B
8-16	B	B	B	B	B	C	C	C	C	C	D	D	D	D	D	A	A	A	A	A	B	B	B	B	B	C	C	C
16-24	C	C	C	D	D	D	D	D	A	A	A	A	A	B	B	B	B	B	C	C	C	C	C	D	D	D	D	D

	NOVEMBER						NOV/DEC					DECEMBER						DECEMBER										
	20	21	22	23	24	25	26	27	28	29	30	1	2	3	4	5	6	7	8	9	10	11	12	13	14	15	16	17
	S	M	T	W	T	F	S	S	M	T	W	T	F	S	S	M	T	W	T	F	S	S	M	T	W	T	F	S
0-8	B	B	B	B	C	C	C	C	C	D	D	D	D	D	A	A	A	A	A	B	B	B	B	B	C	C	C	C
8-16	C	C	D	D	D	D	D	A	A	A	A	A	B	B	B	B	B	C	C	C	C	C	D	D	D	D	D	A
16-24	A	A	A	A	A	B	B	B	B	B	C	C	C	C	C	D	D	D	D	D	A	A	A	A	A	B	B	B

	DECEMBER						DECEMBER					JANUARY 1995						JANUARY										
	18	19	20	21	22	23	24	25	26	27	28	29	30	31	1	2	3	4	5	6	7	8	9	10	11	12	13	14
	S	M	T	W	T	F	S	S	M	T	W	T	F	S	S	M	T	W	T	F	S	S	M	T	W	T	F	S
0-8	C	D	D	D	D	D	A	A	A	A	A	B	B	B	B	B	C	C	C	C	C	D	D	D	D	D	A	A
8-16	A	A	A	A	B	B	B	B	B	C	C	C	C	C	D	D	D	D	D	A	A	A	A	A	B	B	B	B
16-24	B	B	C	C	C	C	C	D	D	D	D	D	A	A	A	A	A	B	B	B	B	B	C	C	C	C	C	D

November 15, 1991

Mr. Ed Mattocks  
International Representative,  
Cement, Lime, **Gypsums** and Allied Workers'  
**AFL-CIO-CFL**

Letter of Intent

During the life of the agreement, October 1, 1991 to September 30, 1994 the Company intends to use Appendix "B", Modes of Operation as follows.

- a) When operating a single kiln operation all employees not required will either be laid-off or transferred to the utility group.
- b) When production is down (no kilns operation) for a period of fourteen (14) days or more the production workers will be:
  - a) laid-off as per article 8.01
  - b) transferred to the utility group
  - c) left on the production shifts

In regard to employees being laid-off article 8.01 will apply in a & b above.

Yours truly,  
ST. LAWRENCE CEMENT, INC.

John P. Duncan  
Director of Personnel and Industrial Relations

October 25, 1991

Mr. Ed Mattocks  
International Representative,  
Cement, Lime, Gypsums and Allied Workers'  
AFL-CIO-CFL

Letter of Intent

Agreement to convene two (2) Labour Management Meetings each year at the Quarry.

The first meeting to take place within two (2) months of ratification.

Items                    - Quarry Hours  
                             - Quarry relief positions  
                             - Clothing

Yours truly,

ST. LAWRENCE CEMENT, INC.

John P. Duncan  
Director of Personnel/Industrial Relations

1991/10/25

Mr. R. Stone  
President Local 366  
United Cement, Lime, Gypsum and Allied Workers'  
International Union Division of Brotherhood of  
Boilermakers  
A.F.L.-C.I.O.-C.L.C.

Letter of Intent     **RE:** Pension Committee

A Joint Committee on the **Mississauga** Hourly Employees Pension Plan will be established, composed of three (3) members appointed by the **Mississauga** Plant, General Manager and three (3) members appointed by the Union. This Committee will have responsibility for:

- A) reviewing the operations of the Pension Plan.
- B) education and information of the Plan participants.
- C) discussing significant developments in the Pensions field.
- D) investigating complaints of participants.
- E) making recommendations to the **Mississauga** Plant, General Manager as deemed appropriate.

The duties of this Committee shall be advisory only.

The Committee will carry out its duties in accordance with the Rules and Regulations of the Retirement Plan for Hourly-Paid Employees at the **Mississauga** Plant which is the official Plan text.

Any proposed changes to these Rules and Regulations is subject to the Company Board of Directors approval.

Regards  
John P. Duncan  
Director of Personnel and Administration  
ST. LAWRENCE CEMENT, INC.

AMENDMENTS AGREED UPON

LETTER OF AGREEMENT

**RE: TECHNOLOGICAL CHANGE**

This letter shall have application when the company introduces new technological changes in the form of capital equipment and such introduction has the initial result of

- a) displacing one or more employees; or
- b) materially changing a job(s) as envisaged by Article 6.02 of the Agreement.**

**Any change(s)** resulting from the above will be handled as follows:

- (1) An employee directly affected by the technological change will be provided a training period of up to **30** days (which may be extended by mutual agreement) on the new or changed job, (providing one exists) created as a result of the new equipment referred to above.
- (2) An employee will be allowed not more than one **opportunity** for training under this Letter of Agreement.
- (3) An incumbent employee selected for training, who is unable to meet the normal requirements of the new or changed job within the **30** day training period (or mutually agreed extension) will be allowed one permanent bump in accordance with Article **7.07** of the Agreement.

The Company **recognized** the Union's concern regarding technological changes which might adversely affect the jobs of the hourly rated employees and therefore, the Company will give not less than thirty days (**30**) notice prior to introducing technological changes as defined above.

The Company will notify laid-off employees by registered mail of the Technological change, allowing the employee(s) to exercise their right under the collective agreement.

1991/10/25

Mr. R. Stone  
President Local **366**  
United Cement, Lime, Gypsum and Allied Workers'  
International Union Division of Brotherhood of  
Boilermakers  
**A.F.L.-C.I.O.-C.L.C.**

Mr. R. Stone President Local **366** Cement Lime Gypsum  
and Allied Worker's Division of Brotherhood of  
Boilermakers **AFL-CIO-CFL**

Letter of Intent **RE:** Early Retirement Program

St. Lawrence Cement will offer the "Concept on Retirement" Program for fifteen (15) employees and their spouses on an annual basis.

This program will be offered on a voluntary first come first served basis with priority given to our more senior (age) employees.

Regards

John P. Duncan  
Director of Personnel and Administration  
ST. LAWRENCE CEMENT, INC.



24 HOUR PERIOD - SUNDAY  
000-2400 SHEET

SUN	001	800
	PAY	
	8 HOURS	
	2X	
000		800

M T	2000	000	0800
	PAY		
	2 X 1½	8 HOURS	
	2 X 2	2X	
2000	000		0800
	SAT		

001	0800	1200
	PAY	PAY
	8 HOURS	2 X 2
	2X	2 X 3
000	0800	1200

0800	1600
	PAY
	8 HOURS
	2X
0800	1600

0400	0800	1600
	PAY	PAY
	2 X 2	8 HOURS
	2 X 3	2X
0400	0800	1600

0800	1600	2000
	PAY	PAY
	8 HOURS	2 X 2
	2X	2 X 3
0800	1600	2000

1600	2400
	PAY
	8 HOURS
	2X
1600	2400

1200	1600	2400
	PAY	PAY
	2 X 2	8 HOURS
	2 X 3	2X
1200	1600	2400

1600	2400	400 MON
	PAY	PAY
	8 HOURS	2 X 1½
	2X	2 X 2
1600	2400	400 MON

OVERTIME ONLY PAID IF REGULAR 8 HOURS WORKED

John P. D...  
FOR THE COMPANY

E. Matlock  
FOR THE UNION

000-2\*00  
**MONDAY - DAY**

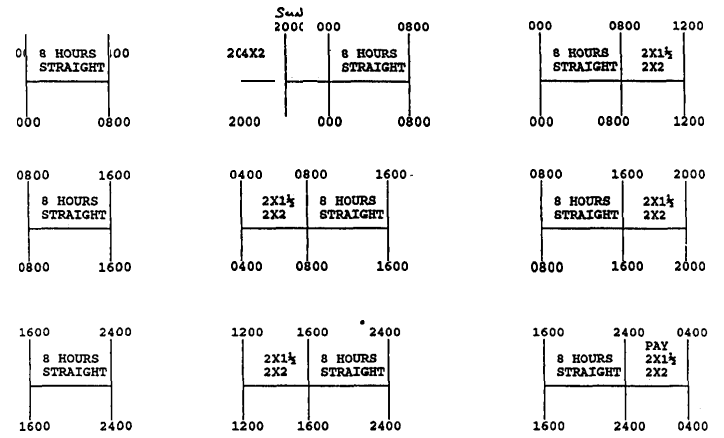

OVERTIME ONLY PAID IF REGULAR 8 HOURS WORKED

John P. 1  
 FOR THE COMPANY

E. Matthews  
 FOR THE UNION

000-2400  
 DAY  
 TUES. WED. THURS. FRI

0000	0800	2000	0000	0800	000	0800	1200
8 HOURS STRAIGHT		2X1 1/2 2X2	8 HOURS STRAIGHT		8 HOURS STRAIGHT		2 X 1 1/2 2 X 2
0000	0800	2000	000	0800	000	0800	1200
8 HOURS STRAIGHT		2X1 1/2 2X2	8 HOURS STRAIGHT		8 HOURS STRAIGHT		2 X 1 1/2 2 X 2
0800	1600	0400	0800	1600	0800	1600	2000
8 HOURS STRAIGHT		2X1 1/2 2X2	8 HOURS STRAIGHT		8 HOURS STRAIGHT		2 X 1 1/2 2 X 2
1600	2400	1200	1600	2400	1600	2400	0400
8 HOURS STRAIGHT		2X1 1/2 2X2	8 HOURS STRAIGHT		8 HOURS STRAIGHT		2 X 1 1/2 2 X 2
0800	1600	0400	0800	1600	0800	1600	2000
8 HOURS STRAIGHT		2X1 1/2 2X2	8 HOURS STRAIGHT		8 HOURS STRAIGHT		2 X 1 1/2 2 X 2

OVERTIME ONLY PAID IF REGULAR 8 HOURS WORKED

*[Signature]*  
 FOR THE COMPANY

*[Signature]*  
 FOR THE UNION

000-1400  
SATURDAY - DAY

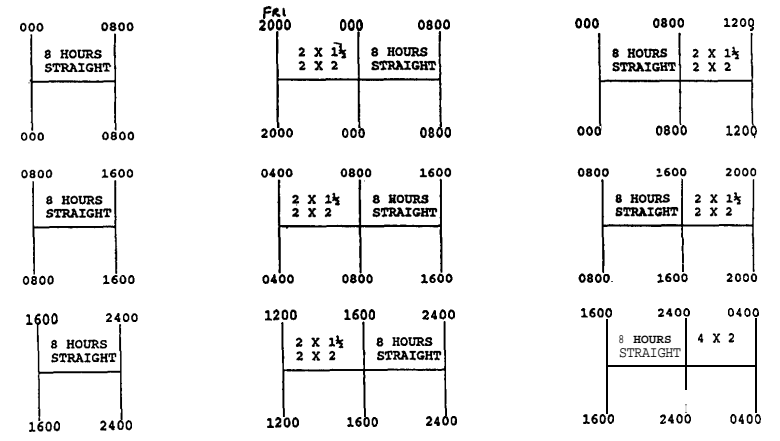

OVERTIME ONLY PAID IF REGULAR 8 HOURS WORKED

DAY WORKERS BAT. PAY 1ST 10 HOURS 1½ OVER 10 HOURS 2X

L. P. [Signature]  
FOR THE COMPANY

E. K. [Signature]  
FOR THE UNION

**0000-2400 SATURDAY - SUNDAY - MONDAY-0000-0800 SHIFT**

SAT	SUNDAY				MONDAY			
2000	0001 2400	0800	1200	1600	2000	0001 2400	0800	1200
2 X 1½ 2 X 2	8 X 2 REGULAR HOURS	2 X 2 2 X 3			4 X 3	8 X 1 REGULAR	2 X 1½ 2 X 2	

2000	0001 2400	0800	1200	1600	2000	0001 2400	0800	1200
2 X 1½ 2 X 2	8 X 2				2 X 2 2 X 3	8 X 1	2 X 1½ 2 X 2	

OVERTIME ONLY PAID IF REGULAR 8 HOURS ARE WORKED

L. P. D.  
FOR THE COMPANY

E. K. M.  
FOR THE UNION

**0000-2400 HOURS SUNDAY-1600-2400 SHIFT**

SAT 1600	SUN 0001 2400	0400	0800	1200	1600	2400	MON 0400
8X1	4X2			4X2	2X2 6X3	2X2 1/2 2X2	

SAT 1600	SUN 0001 2400	0400	0800	1200	1600	2400	MON 0400
8X1	4X2				6X2 2X3	2X2 1/2 2X2	

OVERTIME ONLY PAID IF REGULAR 8 HOURS WORKED

John P. Duncan  
FOR THE COMPANY

Ed Matlocks  
FOR THE UNION

STAT HOLIDAY MONDAY - 1600-2400 SHIFT

SUN 1600	MON 0001 2400	0400	0800	1200	1600	2400	0400
8X2	4X3 1/2*				4X3 1/2*	8X3 1/2*	2X1 1/2 2X2

SUN 1600	MON 0001 2400	0400	0800	1200	1600	2400	0400
8X2	4X3 1/2*					8X3 1/2*	2X1 1/2 2X2

Overtime only paid if regular 8 hours **are** worked.

3 1/2 Times is paid only on the day the statutory holiday is observed.

- 2 Times is paid on statutory holidays for probationary employees.

John P. Duncan  
FOR THE COMPANY

Ed Mattocks  
FOR THE UNION

**0000-2400 STATUTORY HOLIDAY - FRIDAY 0000-0800 SHIFT**

THURS	FRIDAY				SATURDAY			
2000	0001 2400	0800	1200	1600	2000	0001 2400	0800	1200
2 X 1½ 2 X 2	8 X 3½ •	4 X 3½ •				4 X 3½ •	8 X 1	2 X 1½ 2 X 2

THURS	FRIDAY				SATURDAY			
2000	0001 2400	0800	1200	1600	2000	0001 2400	0800	1200
2 X 1½ 2 X 2	8 X 3½ •					4 X 3½ •	8 X 1	2 X 1½ 2 X 2

**OVERTIME ONLY PAID IF REGULAR 8 HOURS ARE WORKED**

**3½ TIMES IS PAID ONLY ON THE DAY, THE STATUTORY HOLIDAY IS OBSERVED**

**2 TIMES IS PAID ON STATUTORY HOLIDAY FOR PROBATIONARY EMPLOYEES**

John P. [Signature]  
FOR THE COMPANY

E. K. [Signature]  
FOR THE UNION



**0000-2400 STATUTORY HOLIDAY - MONDAY 0000-0800 SHIFT**

SUNDAY		MONDAY				TUESDAY			
2000	0001	0001	0800	1200	1600	2000	0001	0800	1200
2400	2400	2400	2400	2400	2400	2400	2400	2400	2400
4 X 2	8 X 3½ *	4 X 3½ *				4 X 3½ *	8 X 1	2 X 1½	2 X 2

SUNDAY		MONDAY				TUESDAY			
2000	0001	0001	0800	1200	1600	2000	0001	0800	1200
2400	2400	2400	2400	2400	2400	2400	2400	2400	2400
4 X 2	8 X 3½ *					4 X 3½ *	8 X 1	2 X 1½	2 X 2

**OVERTIME ONLY PAID IF REGULAR 8 HOURS ARE WORKED**

**3½ TIMES IS PAID ONLY ON TES DAY THE STATUTORY HOLIDAY IS OBSERVED**

**• 2 TIMES IS PAID ON STATUTORY HOLIDAY FOR PROBATIONARY EMPLOYEES**

*Joe P. Di...*  
FOR THE COMPANY

*E. Mat...*  
FOR THE UNION

HOURLY EMPLOYEE SENIORITY LIST

Number	D.O.H.	Badge		Surname	First
		No.:			
1	56/09/13	028		Hoby	John
2	56/09/17	023		Gazzola	Giovanni
3	56/10/09	053		Venturin	Sisto L
4	56/12/17	068		Sciarra	Fausto
5	57/01/02	071		Elioff	Joseph W
6	57/03/11A	083		Kuhlmann	Gunther
7	57/03/11B	035		Folcarelli	Frank
8	57/03/11c	090		Romeo	Nick
9	57/07/15	027		Carnevale	Antonio
10	59/08/25	308		Nelson	Joseph
11	60/02/03	031		Sharpe	Lloyd E
12	61/05/23	038		Prencipe	Giovanni
13	61/07/10	052		Carlesimo	Antonio
14	63/04/14	010		Frieler	Hubert E
15	63/11/10	055		Vienneau	George J
16	63/11/13	041		Duarte	Frank
17	64/09/03	060		Vienneau	Bruno
18	64/09/04	320		Simpson	Norman G
19	65/04/19	004		Aubin	Marcel
20	65/05/17	078		Lenarduzzi	Danilo
21	65/06/01	093		Berube	Maurice S
22	67/05/18	018		Harmel	Reinhold
23	67/05/27	102		Calabrese	Domenico A
24	67/08/17	101		Guay	Gerald
25	68/02/13	014		Burke	Egon
26	69/03/10	110		Cabral	Antonio
27	69/04/05	037		Rolf	Udo W
28	69/09/15	108		Gaetani	Luigi
29	70/05/25A	150		Jandrlic	Marko
30	70/05/25B	143		Hrdina	Paul R
31	70/09/03	183		Bastien	Gerald J
32	70/12/03	201		Silveira	Gilbert D

33	71/02/22	208	Burgum	John V
34	71/03/01	084	Lenarduzzi	Giovanni
35	71/03/08	328	Huizinga	Henry A
36	71/03/12	216	Sisko	Ivan
37	71/03/28	220	Cardinal	Marcel R
38	7 1/04/27	227	Levasseur	Leo B
39	71/05/12	232	Iosue	Guiseppe S
40	71/06/28	239	Gosselin	Arthur-R
41	71/08/03	329	McGregor	Donald W
42	71/11/08	367	Miller	David A
43	72/03/27	106	Munding	Richard
44	72/05/01	075	Ladouceur	Donald
45	72/05/08	123	Sabljak	Anton
46	72/05/ 11	129	Skorija	Franjo
47	72/05/16	128	Laver	Edwin G
48	73/02/12A	109	Campbell	Ian R
49	73/02/12B	135	Courtemanche	Yvan
50	73/03/26A	148	Ball	Gerald
51	73/03/26B	149	Colarusso	Gerald
52	73/04/30	317	Smith	Stanley G
53	73/05/23	318	Clark	Donald T
54	73/05/28	210	Illes	Laszlo
55	73/09/04	253	Sharpe	David L
56	73/09/14	268	Miller	Christopher
57	73/11/12A	133	Richards	Lloyd
58	73/11/12B	235	Ladouceur	Jack A
59	74/02/26	167	Garside	Dennis
60	74/03/05	244	Pinheiro	Jose M
61	74/04/01	272	Morrison	Ronald
62	74/04/08	325	Arthur	Douglas
63	74/05/11	256	McMillan	Ronald
64	74/05/30	502	Pomainville	Pierre R
65	74/06/24	512	Darosa	Lino
66	74/08/21	530	Murdock	Keith R
67	74/08/26	532	Ventresca	Attilio
68	74/09/01	535	Andrade	Jose D
69	74/09/09	542	Jenkins	Robert
70	74/09/25	547	West	Ken
71	74/10/01	549	Pepall	Anthony P

72	74/10/20	554	Sabljak	Drago
73	75/01/22	556	Caputi	Frank
74	75/02/17	157	Moore	Anthony
75	75/06/02	080	Spears	Gerry
76	75/08/09	211	Caron	Patrick J
77	75/08/11	085	Bartley	Michael
78	75/08/26	134	Sterling	Gerald B
79	75/09/17	163	Lawrence	Peter D
80	75/09/22	164	Gilbert	Emile H
81	76/03/08	564	Stojanoski	Kiro
82	76/03/15	565	Groves	David
83	76/05/03	568	Reston	James
84	76/08/24	050	Folcarelli	Nick
85	76/09/07	575	Miller	Stanley C
86	76/09/17	577	Lavoie	Rosaire
87	77/03/08	585	Caron	Roger P
88	77/03/24	589	Pederson	Maynard
89	77/09/12	596	Vandenbroek	William
90	77/09/19	599	Lessard	Vernard
91	77/11/01	260	De Sousa	Lohrenco E
92	78/01/16	219	Berube	Paul
93	78/03/22	122	Castro	Armando
94	78/05/01	051	Calderone	Nicolas
95	78/07/04	236	Laver	Ronald W
96	78/08/08	065	Dalton	Richard
97	78/09/18	066	Morris	Steve G
98	78/10/10	079	Goulart	Jose M
99	78/11/06	347	Rawn	Leslie G
100	79/02/19	103	D'Angelo	Leonard
101	79/04/02	114	Stone	John
102	79/07/03	137	McClellan	Daniel
103	79/09/11	266	Chesterton	Ian D
104	79/10/15	142	Gerada	Emmanuel
105	81/03/17	178	Stone	Ross
106	81/03/23	179	Moore	Steven
107	81/03/30	180	Rummo	Raffaeli
108	81/04/03	361	King	Charles M
109	81/04/06	360	Edison	Richard
110	81/04/20	187	Coyne	Joseph

111	81/05/19	189	Creary	Gordon
112	81/09/13	193	Pratt	Charles
113	81/10/13	364	Greer	James D
114	81/11/03	197	Halas	Bogdan
115	81/11/23	205	Mazur	Jerzy Z
116	82/03/25	212	Vanberk	George
117	82/05/17	222	Frieler	Stefan
118	85/06/21	306	McGlynn	Terry J
119	85/09/03	307	Clark	Fred
120	85/09/23	223	Rawson	Alvin
121	85/09/27	351	Viehbacher	Spencer B
122	86/04/14	370	King	Monty
123	86/07/23	301	Goodfellow	Richard
124	86/12/04B	233	D'Angelo	Gaetano
125	86/12/06	231	Benoit	Wade
126	87/01/05A	234	Heyden	Walter
127	87/01/05B	074	Carry	Robert C
128	87/02/22	238	Parrott	Steven M
129	87/02/25	241	Grodowski	Andrew
130	87/04/23	247	Manchisi	Allesandr
131	87/04/30	248	Kiss	Joseph J
132	87/05/19	249	Iosue	Rick
133	87/06/12	250	O'Neill	Kevin
134	87/11/12	254	Cherry	Douglas
135	87/12/15	251	Skeoch	Jay
136	88/02/07	259	Pratt	Steven
137	88/02/08	258	Moccia	Thomas
138	88/03/28	261	Brown	Eric
139	88/04/11	371	Germaine	Michael
140	88/04/18A	263	Forjan	Zvonko
141	88/04/18B	264	Iosue	Mario
142	88/05/03	274	Nobre	Pedro L
143	88/07/04	280	Gielen	Nickolas J
144	88/07/11	282	Amyotte	Steve
145	88/07/25	283	Bradshaw	Dan
146	88/12/12A	578	Baldauf	Albert
147	88/12/12B	579	Daponte	John
148	89/01/16	580	Silveira	James R
149	89/02/14	581	Dunlop	Michael

150	89/09/19	588	Folcarelli	Luigi
151	89/10/23	591	Stirton	Robert
152	89/10/30A	592	Slanic	William
153	90/01/29	595	Aubin	Jean-Marc
154	90/02/12	513	Vaillancourt	Pierre
155	90/02/19	597	Vanberk	Dirk
156	90/02/26	514	Pacheco	Gilbert
157	90/03/10	516	Lake	James
158	90/03/11	518	Paolucci	Robert
159	90/03/12	517	Lenarduzzi	Dave
160	90/03/13	515	Ladouceur	Rene
161	90/04/16	305	Simpson	William M
162	90/04/30	520	Partyka	Adam
163	90/05/08	002	Goulart	Edward
164	90/05/14	521	Aubin	Serge R
165	90/05/22	003	Boardman	R. Edward (Ted)
166	91/03/18A	007	Hawtin	Bruce
167	91/03/18B	006	Carroll	Thomas
168	91/04/17	009	Macdonald	Alan
169	91/04/22	008	Schmalz	Glenn

IN WITNESS WHEREOF each of the parties hereto has caused this Agreement to be signed in their respective names by their duly **authorized** representatives.

ST. LAWRENCE CEMENT, INC.  
MISSISSAUGA, ONTARIO

Mr. C. Coles  
General Manager

Mr. J. P. Duncan  
Director of Personnel and Industrial Relations

Mr. W. McGrath  
Labour Relations and Safety Supervisor

Mr. T. Anderson  
Director of Engineering

Mr. H. D. Hofmann  
Production Manager

Mr. F. Toffoli  
Maintenance Manager

Mr. R. David  
Controller

Mr. E. Smith  
Chief Chemist

CEMENT, LIME, GYPSUM AND ALLIED WORKERS'  
DIVISION OF BROTHERHOOD OF BOILERMAKERS,  
IRON SHIP BUILDERS, BLACKSMITHS, FORGERS  
AND HELPERS. AFL-CIO-CFL.

Mr. E. Mattocks  
District Representative

Mr. R. Stone  
**President**

Mr. L. Illes  
Plant Union Chairman

Mr. T. Moore  
Committee Member

Mr. D. Ladouceur  
Committee Member

Mr. B. Jenkins  
Committee Member

Mr. H. Bradshaw  
Committee Member